

ALEA

ATREO



ATREO

why atreo

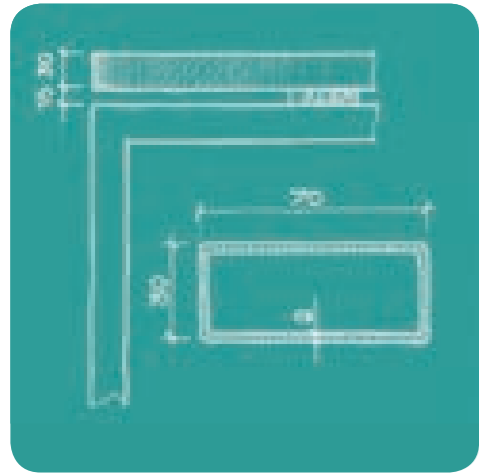
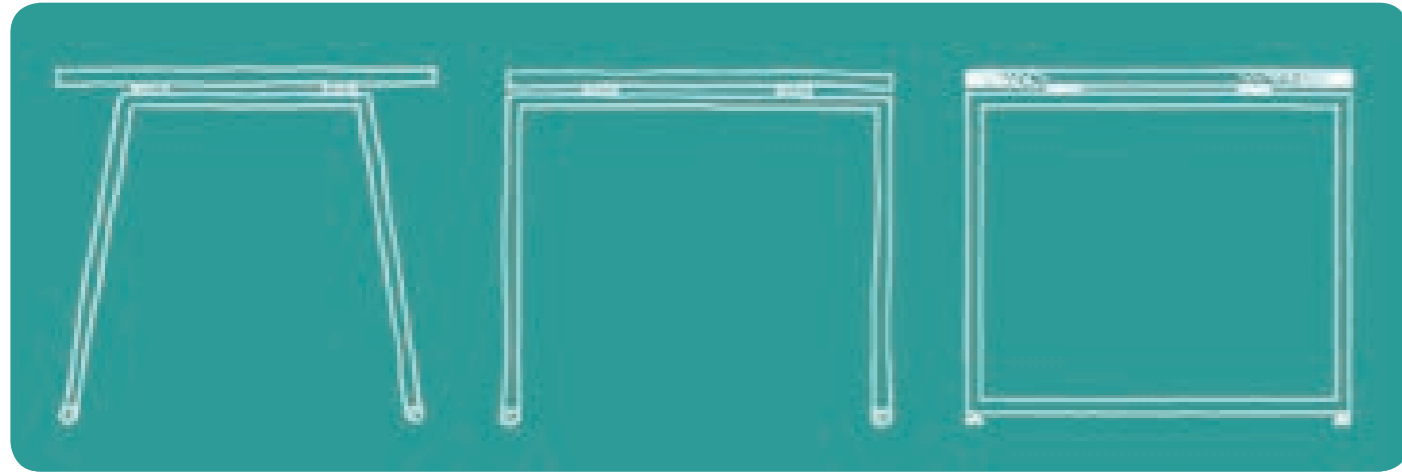

geometry

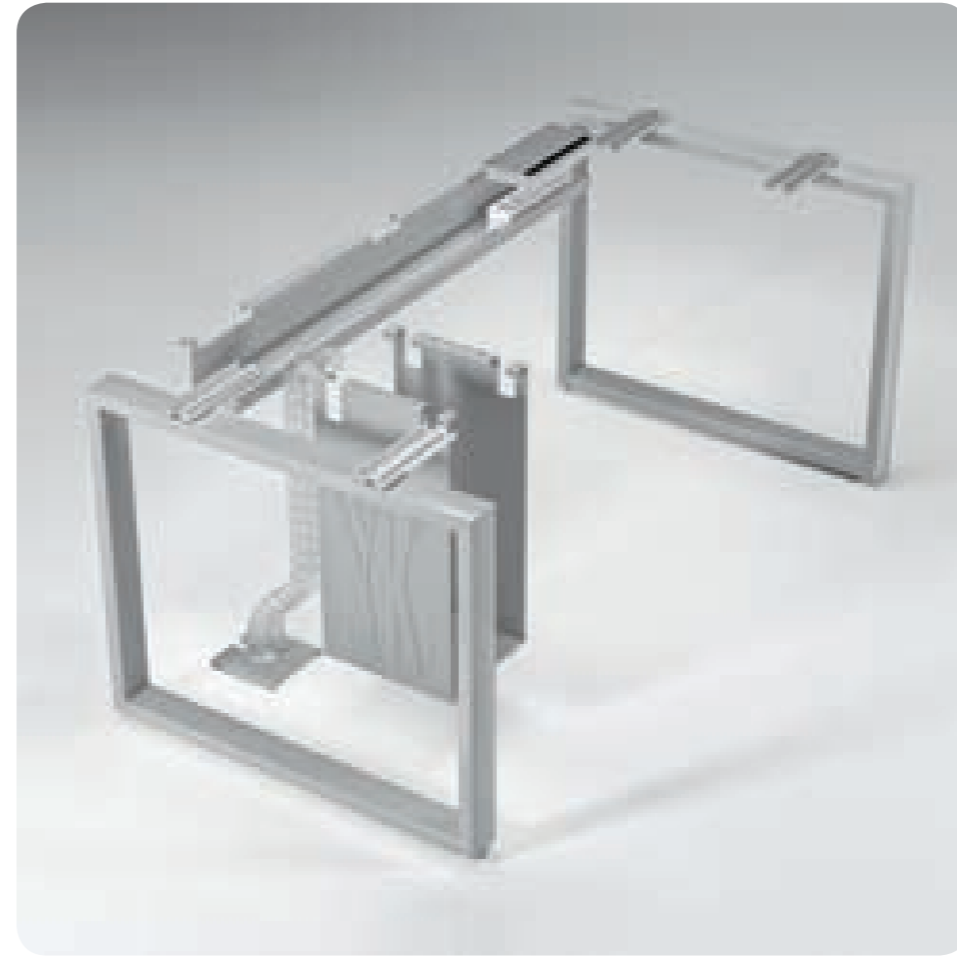
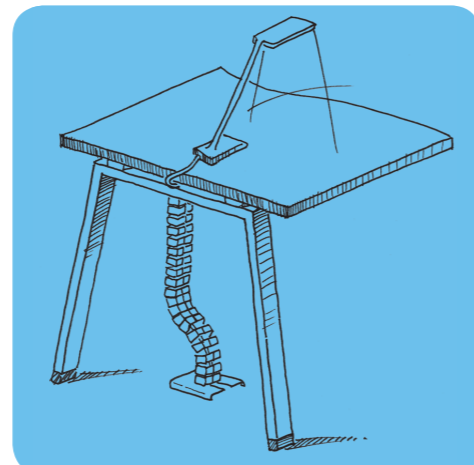

frames

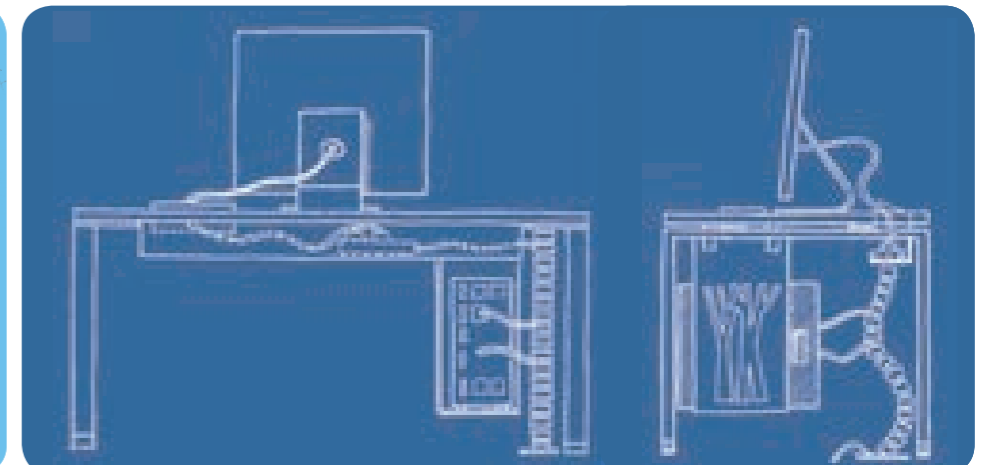
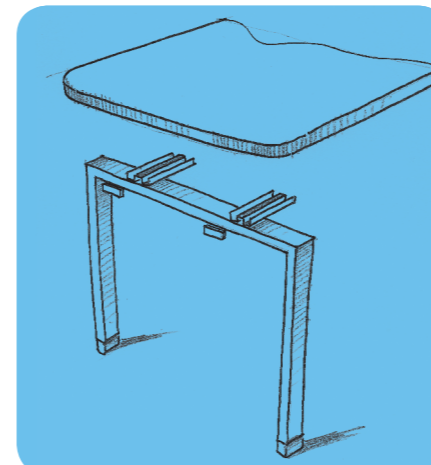

wiring



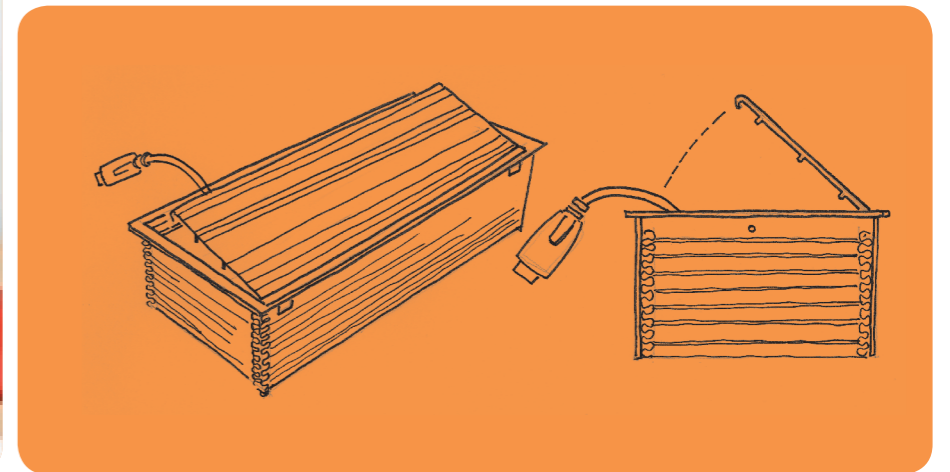
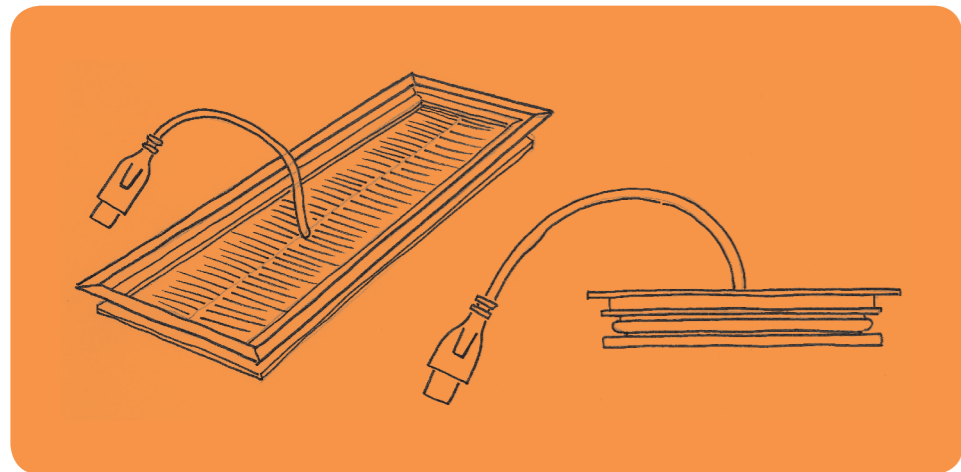
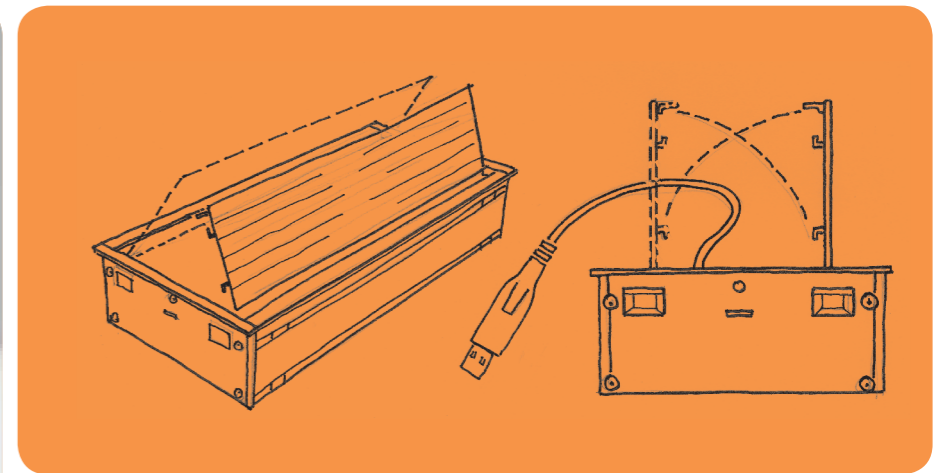
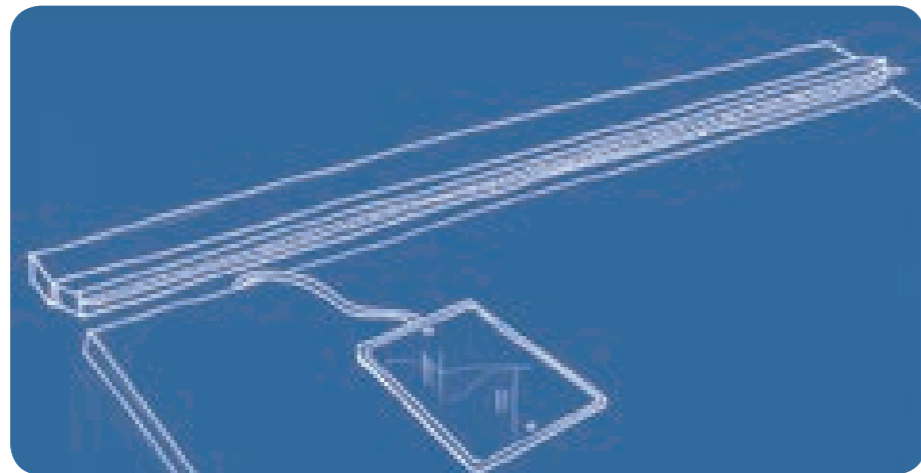
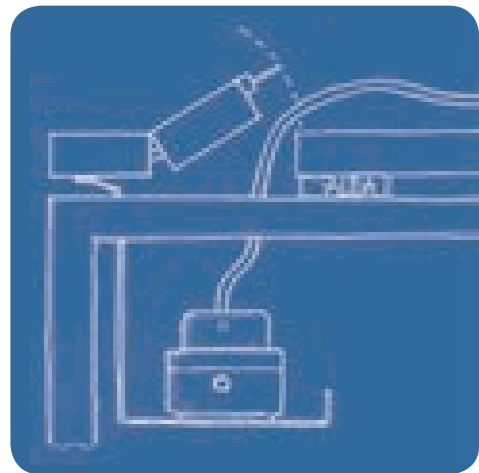
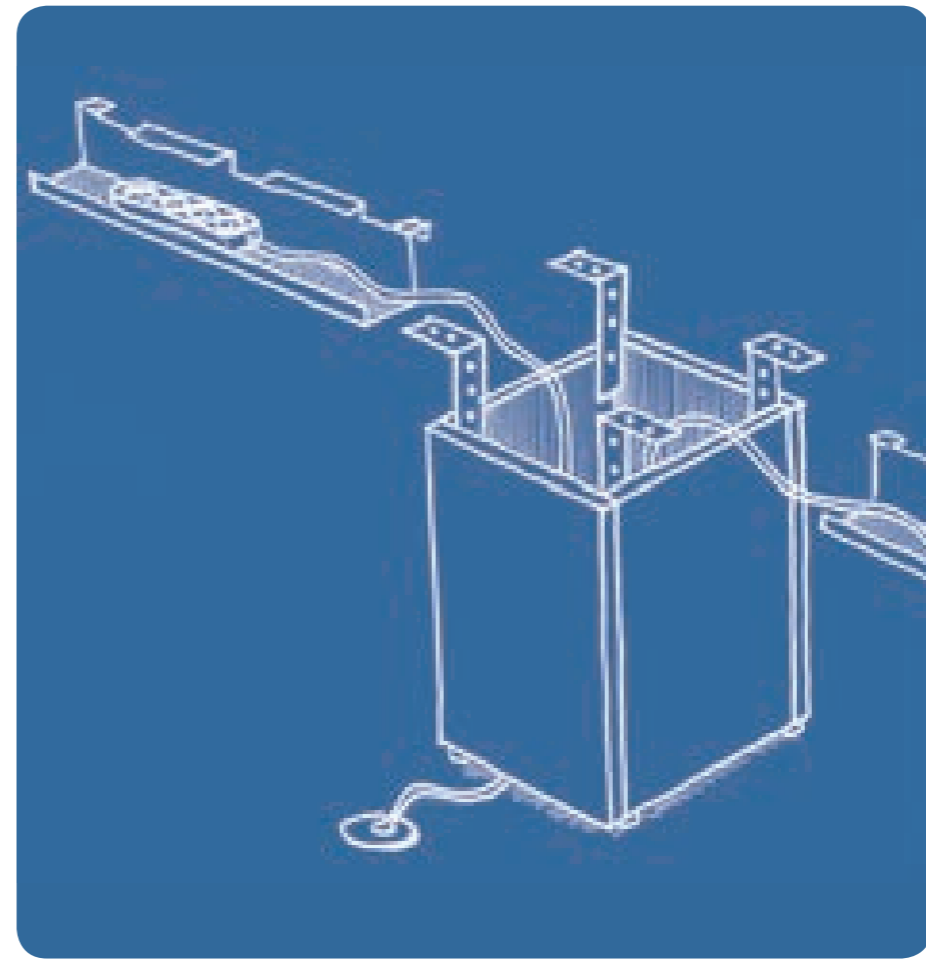
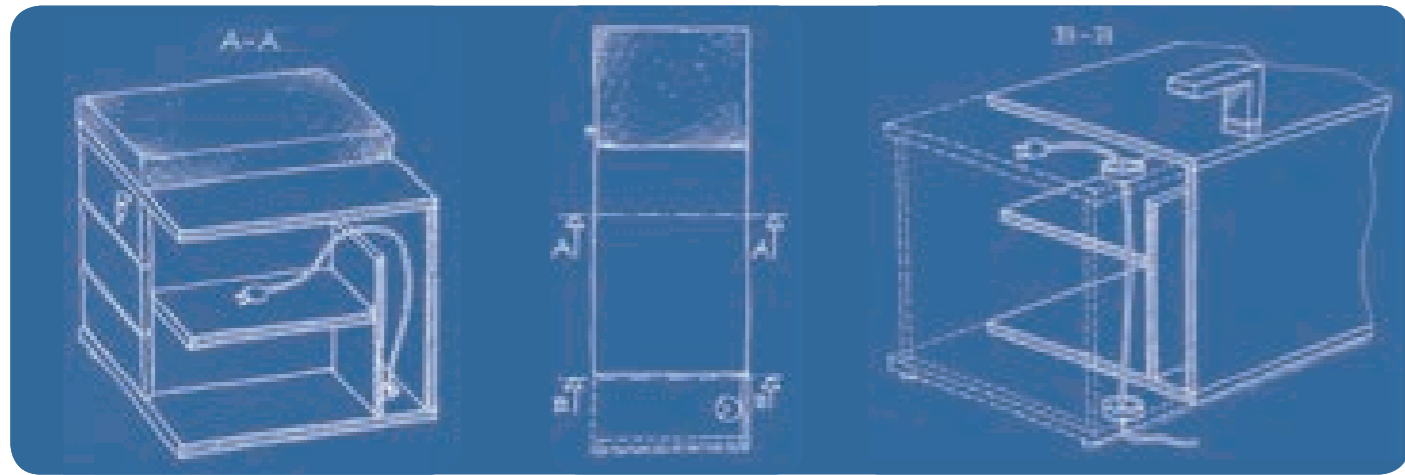

ATREO



4



5







Atreo features also square table tops with rounded corners. In this case the legs are recessed and the suspended returns are offering a more operative solution (the picture shows only the side corners with the curved angles).

Atreo offre également des plans carrés avec des coins arrondis. Les tables en cette option ont comme structure des pieds en retrait et peuvent aussi recevoir des retours accroches. (dans ce cas, le rayon ne concerne que les coins libres).

Atreo también tiene opciones con cubiertas cuadas y esquinas redondeadas. En este caso las patas estan retrasadas y los retornos ofrecen una superficie mas operativa. (en la foto el radiado se encuentra en las esquinas libres).



Atreo presenta anche piani quadrati con angoli arrotondati. I tavoli con questa opzione vengono sostenuti da gambe rientranti e possono essere completati da piani dattilo addizionali (in questo caso la raggiatura riguarda solo gli angoli liberi).











ATREO



ATREO signature feature is the metal leg (straight or angled). The leg supports worktops 30 mm thick (1 3/16") rectangular or shaped. In the benching configurations face to face a center support can replace the intermediate leg and function as a riser to conceal cables and as the ideal location for a floor grommet.

Atreo se caractérise par son pied métallique droit ou incliné qui supporte les plans de travail d'épaisseur de 30mm. Ces plateaux en mélaminé existent en forme compact ou rectangulaire. Plusieurs emplacements existent pour positionner soit un pied intermédiaire, soit un support en mélaminé spécifique pour le stockage des câbles.

ATREO se caracteriza por su pata puente (recta o a trapezoidal) que soporta las superficies en laminado melamínico de 30mm de grueso, que pueden ser rectas o de formas variadas. En las configuraciones de escritorios múltiples enfrentados la pata intermedia puede ser reemplazada por un soporte central hueco que permite además el manejo de los cables.



ATREO si caratterizza per la gamba metallica a cavalletto (dritta o angolare) a sostegno di piani lavoro in nobilitato melaminico di spessore 30 mm di forma ortogonale o sagomata. Nelle postazioni multiple contrapposte, la gamba intermedia viene sostituita da supporti centrali in melaminico adatti al contenimento dei cavi.

ATREO



La gamba di ATREO, realizzata in profilo di metallo verniciato a polveri epossidiche, è disponibile in 10 colorazioni di serie. Al colore della struttura possono essere abbinati gli screen agganciati in metacrilato, le cassettiere e gli armadi con ante piene in melaminico o in metacrilato con telaio in alluminio.

The ATREO leg, made of metal epoxy powder coated, comes in 10 standard colours. Those colours can be combined with matching colours of the acrylic screen, pedestals and storage door fronts.

Le pied métallique Atreo, verni à poudres époxydes, est désormais disponible en 10 couleurs standards. Les écrans, les portes pleines en mélaminé ou en acrylique, les caissons et les accessoires métalliques pourront être assortis à la structure.

La pata estructural de ATREO realizada en acero barnizado con polvos epoxy, está disponible en 10 colores de serie, los cuales se pueden coordinar con las mamparas colgadas acrílicas, las cajoneras y armarios, ya sean de puertas sólidas o con inserciones acrílicas con marco de aluminio.



24



25



The screen dividers are available in different materials: melamine, lacquered, acrylic or tackable fabric with sound absorbing features. The same materials can be applied to fronts and backs of storage cabinets.

Les écrans sont disponibles dans différentes matières: mélaminé, laqué mat, méthacrylate ou encore dans un matériau "tackable" acoustique. Ce dernier peut être appliqué comme revêtement des dos d'armoires ainsi que pour les façades des armoires avec portes coulissantes.

Las mamparas se fabrican en varios materiales y acabados: en laminado melamínico, en aglomerado lacado opaco, en acrílico y también en material perforado y acústico. Con el mismo material se pueden forrar los frontales y traseras de los armarios de puertas correderas.



Gli screen dividers sono disponibili in materiali diversi: in melaminico, in laccato opaco, in metacrilato oppure in materiale 'tackable' fonoassorbente. Lo stesso materiale può essere utilizzato per il rivestimento di fronti e schiene dei contenitori in melaminico con ante scorrevoli modulari.



Atreo has a new and functional side storage cabinet equipped with an integral pedestal and CPU holder. The cabinet provides storage and supports the desk. The cushion placed over the pedestal allows the user (or guest) to use the cabinet as a seat.

Les plans de travail avec angles arrondis, disponibles en version simple ou double en vis à vis, pouvant se poser aussi sur les rangements latéraux avec blocs tiroirs et niche UC intégrés, offrent de nouvelles réponses esthétiques et fonctionnelles. Le coussin placé sur le bloc tiroirs permet une assise d'appoint pour l'utilisateur ou le visiteur.

Las superficies o encimeras con esquinas redondeadas, sencillas o dobles, apoyadas en muebles auxiliares con cajonera y porta CPU integrado, ofrecen soluciones estéticas y funcionales originales. El cojín opcional transforma la cajonera en una sillita informal.



I piani scrivania con angoli arrotondati, singoli o doppi, sovrapposti a contenitori laterali con cassettiere e porta CPU integrati, offrono nuove soluzioni estetiche e funzionali. Il cuscino sovrapposto alla cassettiere consente all'operatore (o al visitatore) di utilizzare il contenitore come seduta.



The ATREO wave tops allow you to create different table configurations with multifunctional use. With the several finishes available for tops and legs, multiple colour combinations can be arranged.

Les plans courbe d'Atreo permettent la conception de tables multi fonctionnelles curvilignes. De nombreuses options de finitions couleur existent tant pour les plans que pour les pieds.

Con las superficies curvas de ATREO se pueden realizar mesas multifuncionales. La gran variedad de acabados para las estructuras y superficies permiten múltiples combinaciones de colores.



Con i piani curvati di ATREO si possono realizzare tavoli polifunzionali curvilinei. Le numerose opzioni di finitura per piani e gambe consentono molteplici combinazioni di colore.



Pensati per biblioteche e sale lettura, i tavoli ATREO di forma sagomata abbinati a screen in metacrilato curvati (a seguire il design del piano) conferiscono all'ambiente freschezza e creatività.

Designed initially for libraries and reading rooms, ATREO wave tables and screens deliver freshness and creativity to the site.

Conçus pour les bibliothèques et les salles de lecture, les tables Atreo de forme courbe associés aux écrans de séparation en méthacrylate (suivant la forme du plateau) apportent fraîcheur et créativité à l'ambiance.

Diseñadas para bibliotecas y salas de lectura, las mesas ATREO de formas curvas combinadas con las mamparas en acrílico del mismo diseño brindan frescura y creatividad.





ATREO





P551911 Gamba a cavalletto / A-shape leg / Piètement trèteau / Pata de caballete

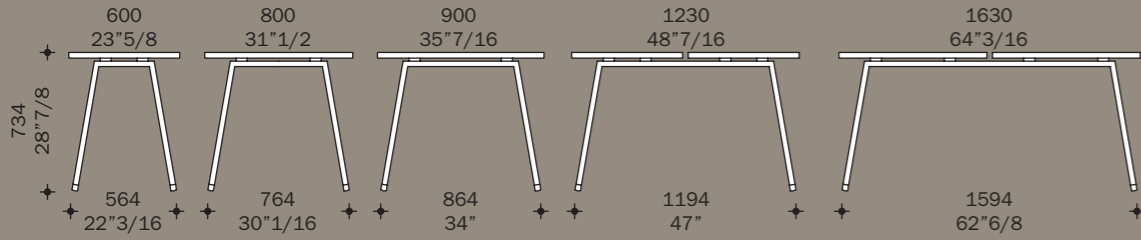

P551913



P551914

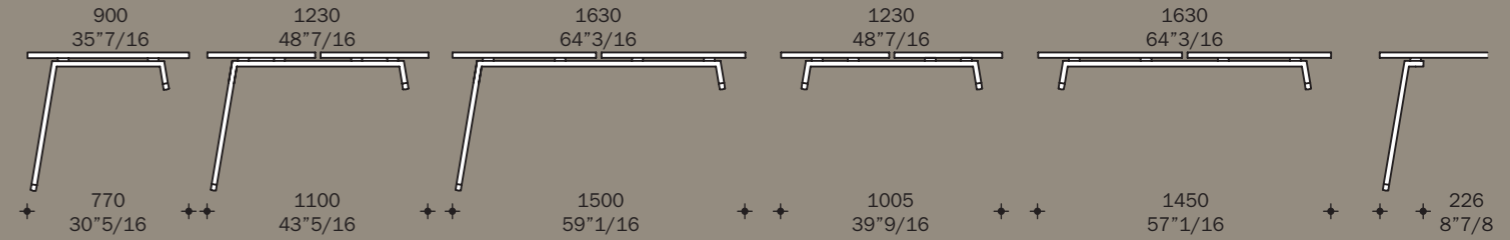

P5519P11

P551912 Gamba a cavalletto regolabile / Adjustable A-shape leg / Piètement trèteau réglable en ht. / Pata de caballete regulable en altura

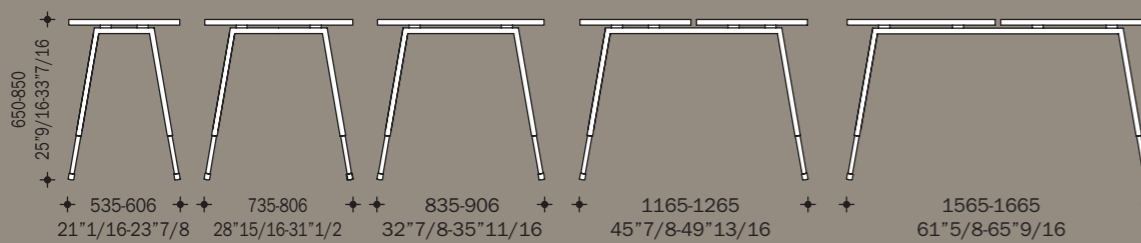

P551921 Gamba a ponte / Straight leg / Piètement droit / Pata recta

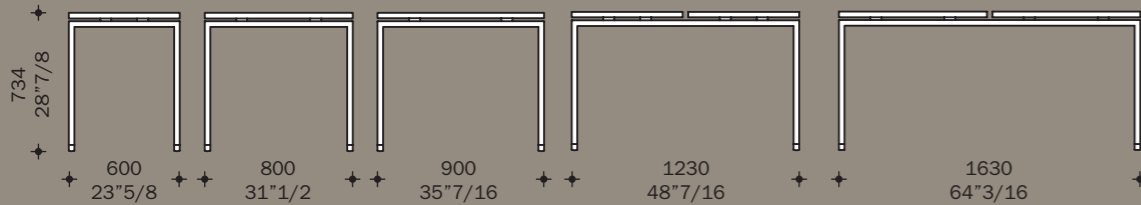

P551923

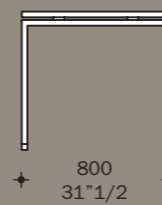

P551924

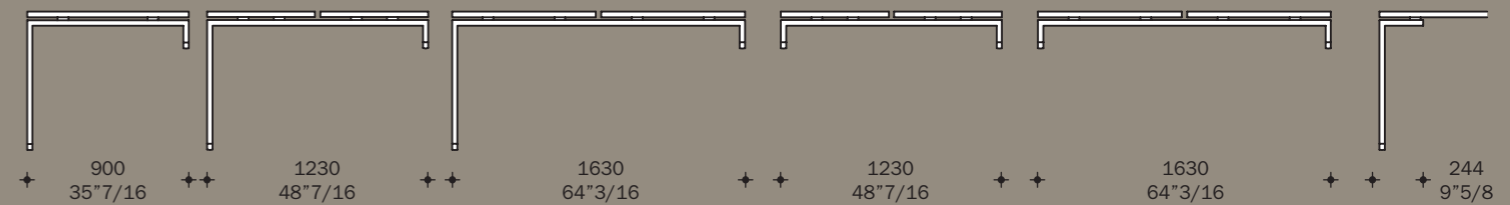

P5519P21

P551921 Gamba a ponte / Straight leg / Piètement droit / Pata recta

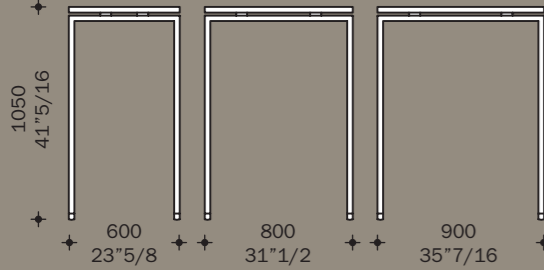

P551921 Gamba a ponte regolabile / Adjustable straight leg / Piètement droit réglable en ht. / Pata recta regulable en altura

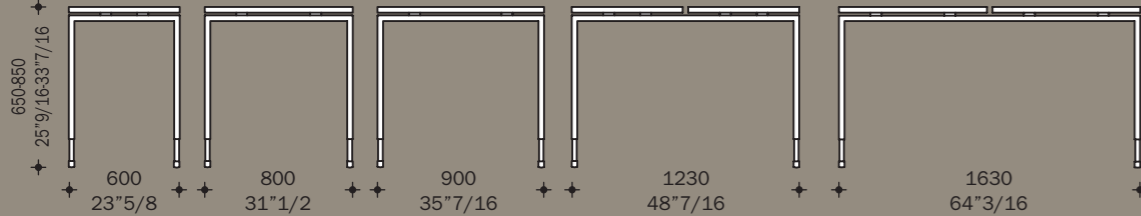

P551821

Gamba a ponte tavolino caffè / Coffee table straight leg
Pied droit petite table à café / Pata recta mesa para café



P5518A1

Gamba ad anello tavolino caffè / Coffee table closed loop leg
Pied fermè petite table à café / Pata anillo mesa para café

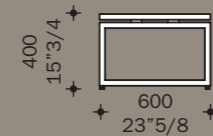

Basamento / Base for bench solution / Base de support bench / Columna central para bench

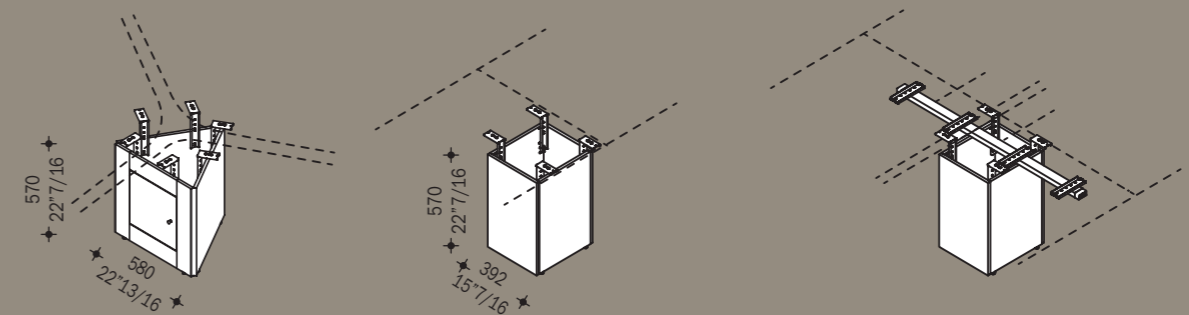

P5519T

Basamento triangolare 120°
Base for cluster solution 120°
Base triangulaire 120°
Columna central para bench 120°











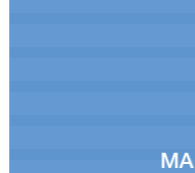

P5519M

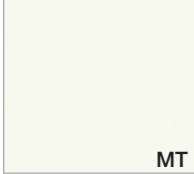
Basamento bench singolo
Bases for bench solution
Base de support
Columna central para bench sencillo

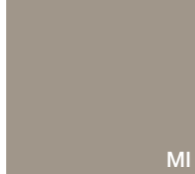
P5519MT

Basamento bench doppio
Bases for bench solution
Base de support
Columna central para bench doble

Melaminico Melamine Melaminé Melamin Melaminico















 Bianco rigato Rippled effect white Blanc avec rayures en sérigraphie Linierte weiß Blanco rayado	 Grigio rigato Rippled effect grey Gris avec rayures en sérigraphie Linierte grau Gris rayado	 Arancione rigato Rippled effect orange Orange avec rayures en sérigraphie Linierte orange Naranja rayado	 Azzurro rigato Rippled effect blue Bleu avec rayures en sérigraphie Linierte blau Azul rayado	 Verde rigato Rippled effect green Vert avec rayures en sérigraphie Linierte grün Verde rayado	 Bianco White Blanc Weiß Blanco
 Talco Talco Talco Talco Talco	 Ardesia Ardesia Ardesia Ardesia Pizarra	 Noisette Noisette Noisette Noisette Noisette	 Rovere grigio Grey oak Chêne gris Grau eichenholz Roble gris	 Rovere chiaro Light oak Chêne clair Helles eichenholz Roble claro	 Rovere moro Dark oak Chêne foncé Dunkles eichenholz Roble oscuro
 Noce Canaletto Canaletto Walnut Noyer Canaletto Nußbaum Canaletto Nogal Canaletto	 Noce Chiaro Walnut Noyer Nußbaum Nogal	 Rovere americano American oak Chêne américain Amerikanischer eichenholz Roble americano			

Strutture Frames Structures Structure Estructuras

 Bianco White Blanc Weiß Blanco	 Grigio Grey Gris Grau Gris	 Noisette Noisette Noisette Noisette Noisette	 Ardesia Ardesia Ardesia Ardesia Pizarra	 Verde Green Vert Grün Verde	 Arancione Orange Indigo Orange Naranja
 Azzurro Blue Beu Blau Azul	 Bronzo Bronze Bronze Bronze Bronce	 Sabbia Cream Sable Beige Arena	 Nero Black Noir Schwarz Negro	 Talco Talco Talco Talco Talco	

• Le finiture contenute nel presente catalogo sono puramente indicative e non sono di riferimento per le forniture del prodotto.
• Due to the printing process, finishes shown in this catalogue are for illustration only. The finish on the final item may differ slightly from the printed illustration.

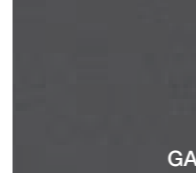
Goffrato Embossed Gaufré Matt lackiert Gofrado

 Goffrato Moka Embossed Mocha Gaufré Moka Matt lackiert Mokka Gofrado Cafe	 Goffrato Indaco Embossed Indigo Gaufré Indigo Matt lackiert Indigoblau Gofrado Azul Indigo	 Goffrato Rubino Embossed Ruby Gaufré Rubis Matt lackiert Rubinrot Gofrado Rubi	 Goffrato Cedro Embossed lime green Gaufré vert Cédrat Matt lackiert Zitronatgrün Gofrado verde Cedro	 Goffrato Argento Embossed Silver Gaufré Argent Matt lackiert Silber Gofrado Plata	 Goffrato bianco Embossed white Gaufré blanc Matt lackiert weiß Gofrado blanco
 Goffrato nero Embossed black Gaufré noir Matt lackiert schwarz Lacado negro	 Goffrato rosso "F" Embossed red "F" Gaufré rouge "F" Matt lackiert Rot "F" Lacado rojo "F"	 Goffrato arancione Embossed orange Gaufré indigo Matt lackiert orange Lacado naranja	 Goffrato grigio scuro Embossed grey Gaufré gris Matt lackiert grau Lacado gris	 Goffrato azzurro Embossed blue Gaufré bleu Matt lackiert blau Lacado azul	 Goffrato verde Embossed green Gaufré vert Matt lackiert grün Lacado verde
 Ardesia Ardesia Ardesia Ardesia Pizarra	 Noisette Noisette Noisette Noisette Noisette				

• Les finitions contenues dans ce catalogue ne sont pas contractuelles - les photos ne pouvant rendre la parfaite réalité.
• Die Farbwiedergabe dieses Katalogs kann aus drucktechnischen Gründen von den fertigen Produkten abweichen. Ebenso sind technische und konstruktive Änderungen zur Modell-Optimierung möglich.
• Los acabados contenidos en este catálogo son puramente indicativos y no son de referencia para los suministros del producto.

Metacrilato Metacrylate Méthacrylate Acrylglas Metacrilato

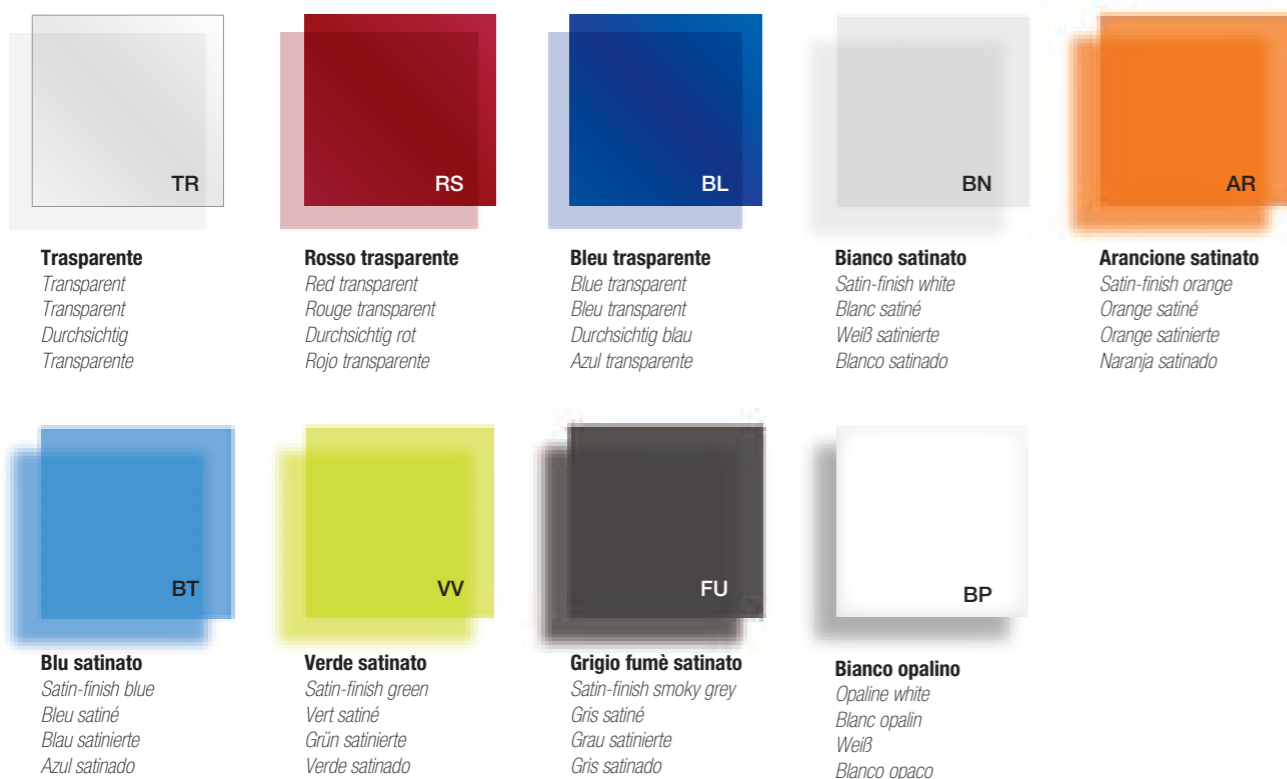

design
Filippon

art direction
Mirto Antonel

AF/CABD/AA

Tessuto Fabric Tissu Stoff Tejido

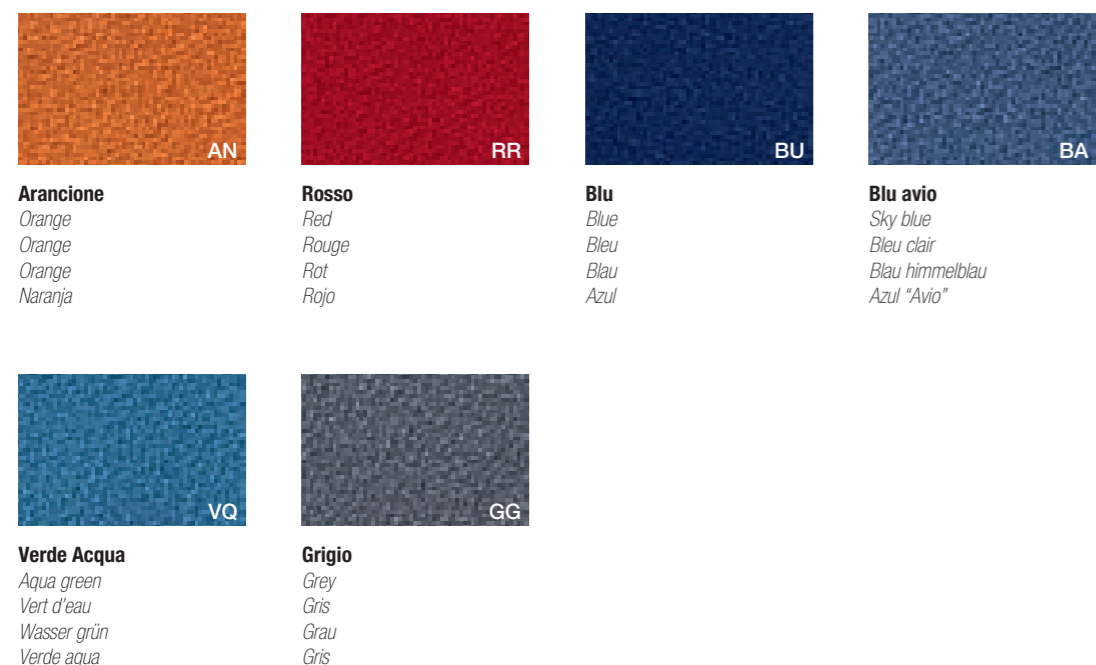

- Le finiture contenute nel presente catalogo sono puramente indicative e non sono di riferimento per le forniture del prodotto.
- Due to the printing process, finishes shown in this catalogue are for illustration only. The finish on the final item may differ slightly from the printed illustration.
- Les finitions contenues dans ce catalogue ne sont pas contractuelles - les photos ne pouvant rendre la parfaite réalité.
- Die Farbwiedergabe dieses Katalogs kann aus drucktechnischen Gründen von den fertigen Produkten abweichen. Ebenso sind technische und konstruktive Änderungen zur Modell-Optimierung möglich.
- Los acabados contenidos en este catálogo son puramente indicativos y no son de referencia para los suministros del producto.