

# Movinord

Office Concept

# Advantages of mobile solutions

## Maximum space leverage

The "mobile" **Eun Grupo** solutions feature a series of advantages that give them the edge over other options on the market.

Technical and technological breakthroughs that have been maintained in different generations of **Eun Grupo** solutions, which have evolved progressively and intensely.

Thus, **Eun Grupo** delivers, through its **EunMobile** product, which permits "mobile" space management, a breakthrough in evolution with regard to its equally varied offer of products for "static" space management.



eunSHELVING



eunmobile



eunmobile (E)



eunMatic

The next stage in the evolution arose with the addition of motorisation to the mobile concept, thus rendering space management more agile.

The cutting edge of this evolution is represented by the electronic automation of this motorisation, conferring upon the product the maximum level of characteristics in terms of versatility, flexibility and safety in space management.



eunMatic



eunTRONIC

# space in movement











The ability to move one space to create another is the basis on which this product line was conceived. This capacity provides the advantage of optimal space leverage. This maximum facility of movement delivers perfect access to the spaces derived from it, creating new opportunities in the form of highly accessible spaces.











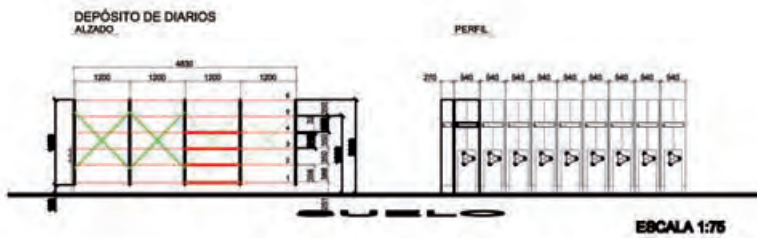
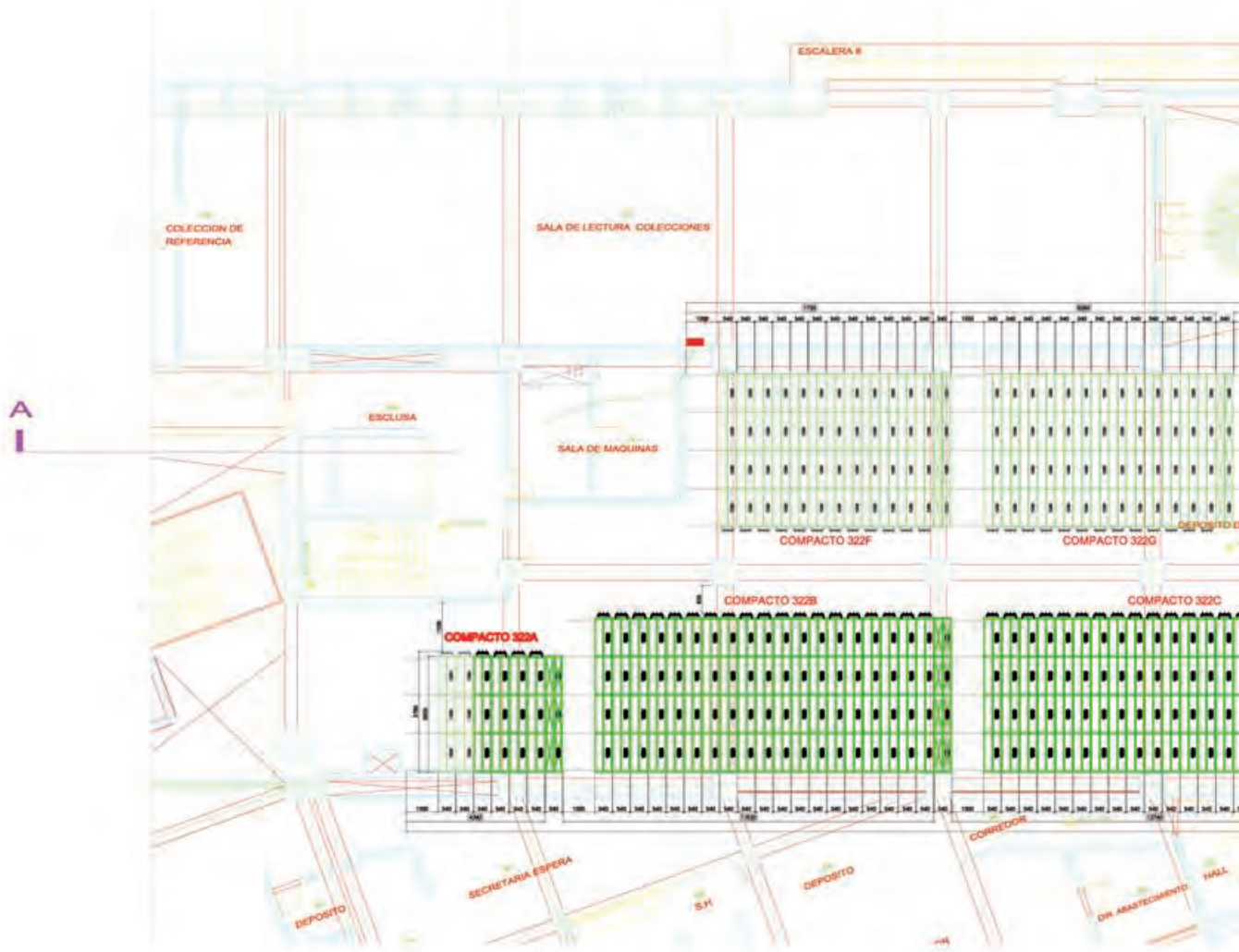

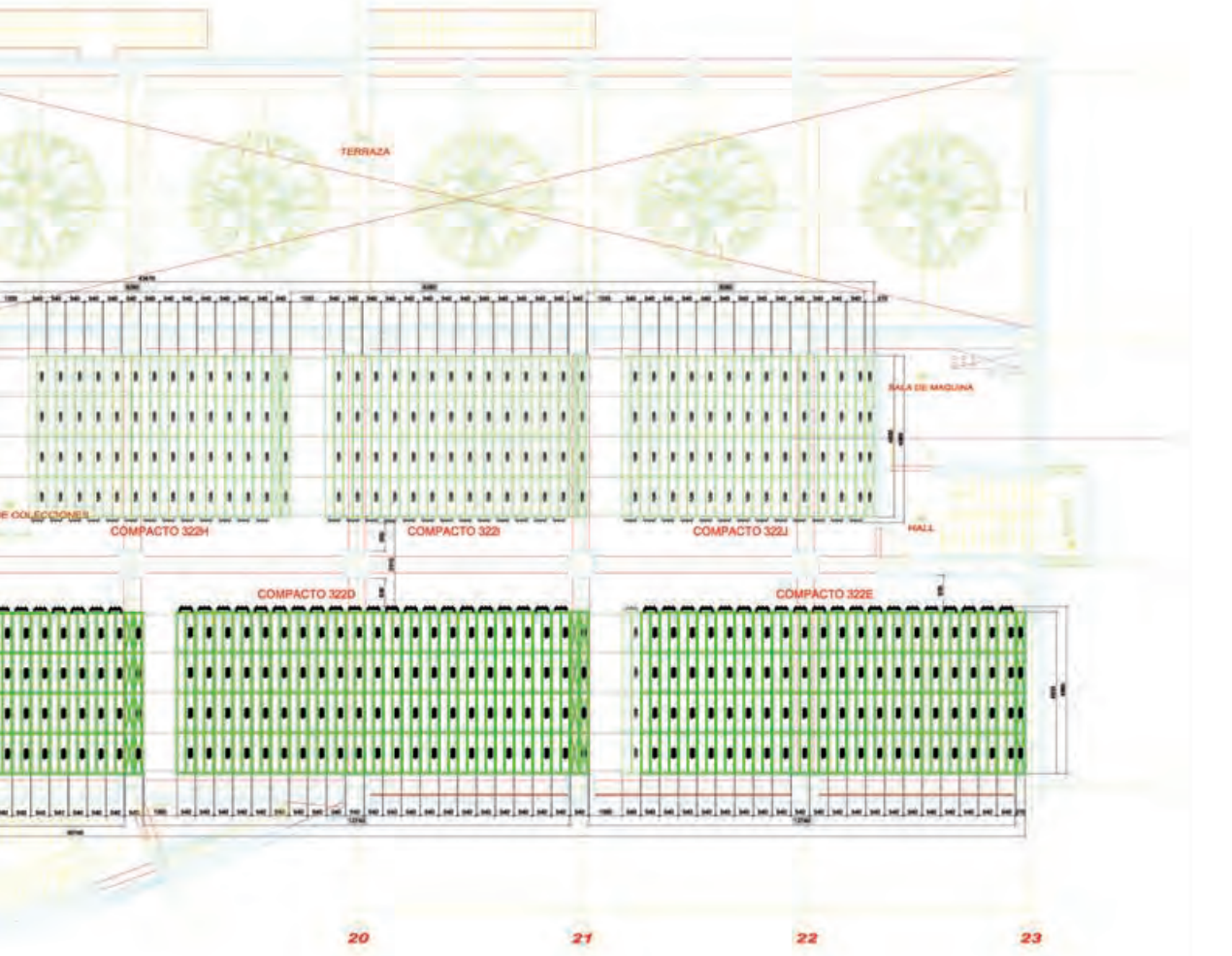

**322 - DEPÓSITO DE COLECCIONES**

Capacidad Total de la Instalación..... 9.172,8 m Totales  
 Capacidad Utili de la Instalación..... 7.644 m Útiles + Balda Techo

**MONOGRAFIA**



Capacidad de la Instalación..... 146.510 MONOGRAFIAS

**PLANTA TERCER PISO  
SECTOR 2**

**CAPACIDADES DE CARGA POR BALDA Y FLECHA**

Balda de 1200	
kg	Flecha
80	5mm
120	7,5mm

Escala Gráfica



Planchado	INCLUIDO	Aluminio	Observación	Código	COB501
Revestido	INCLUIDO	Aluminio	Observación	Código	COB502
Verificado					
Orden	CUBIERTA		Materia	Acabado	Escala
Nº de plano	MONOGRAFIA		MATERIAL	ACABADO	ESCALA
Nº de plano					
			Tipo de Modificación 01 TIPO DE MODIFICACION 02 03		Plano N. <b>PLANO_Nº</b>
eun grupo Ingeniería y Construcción de Librerías y Bibliotecas S.L. - eun grupo S.L.A. Calle de la Industria, 10 28014 Madrid - España T: +34 91 494 1000 F: +34 91 494 1001 www.eun-grupo.com			Sustituido por: Sustituido por:		
Este plano es propiedad de eun grupo S.L.A. cualquier préstamo o reproducción a terceros sin autorización previa escrita de eun grupo.					



**Implementation EunMobile**



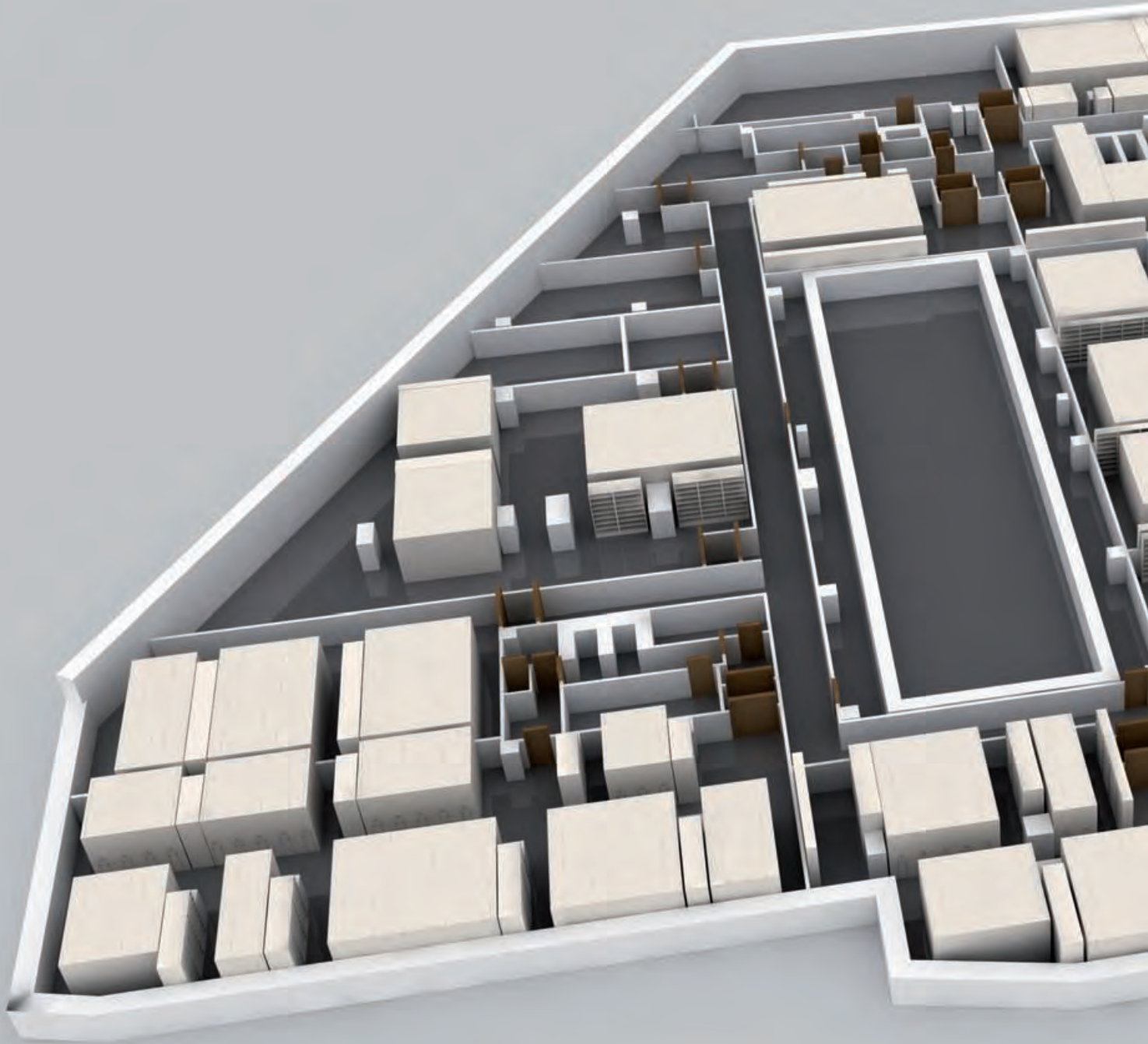

**Implementation EunMobile Class E**

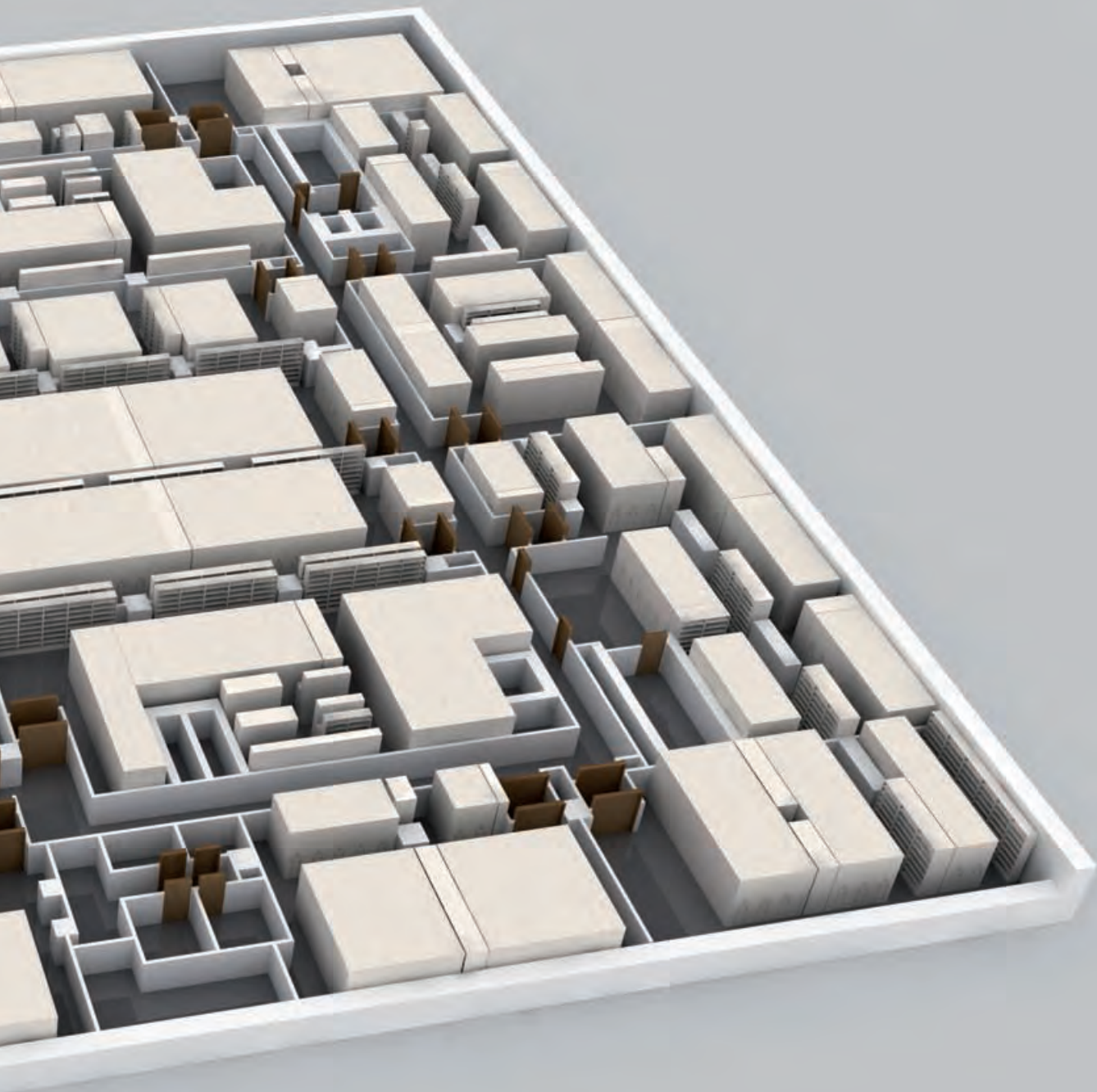



# Advantages of the EunMobile system

1

The application of the “mobile” concept in this product provides the capacity to create space simply by moving one or several carriages.

Static Syst.

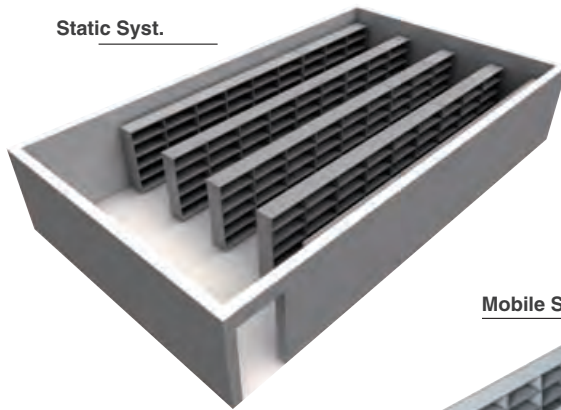

Mobile Syst.

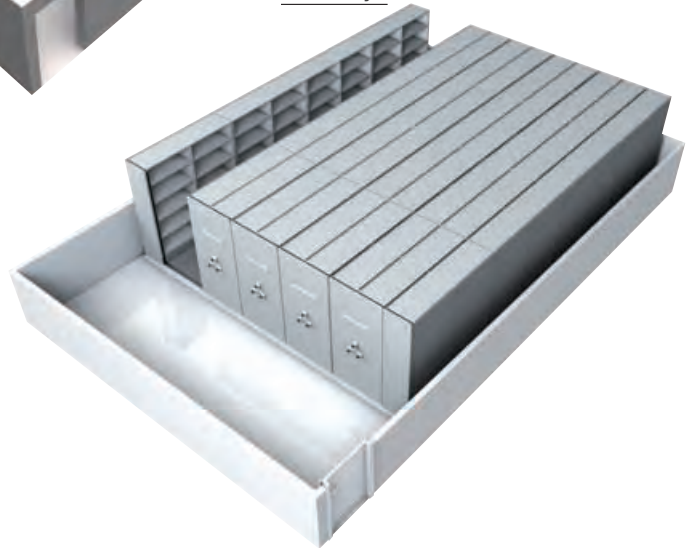

2

The only requirement to make this system “mobile” is the need to have an access corridor, which entails the possibility of practically “duplicating” the space storage capacity versus “static” storage systems.

Access Corridor

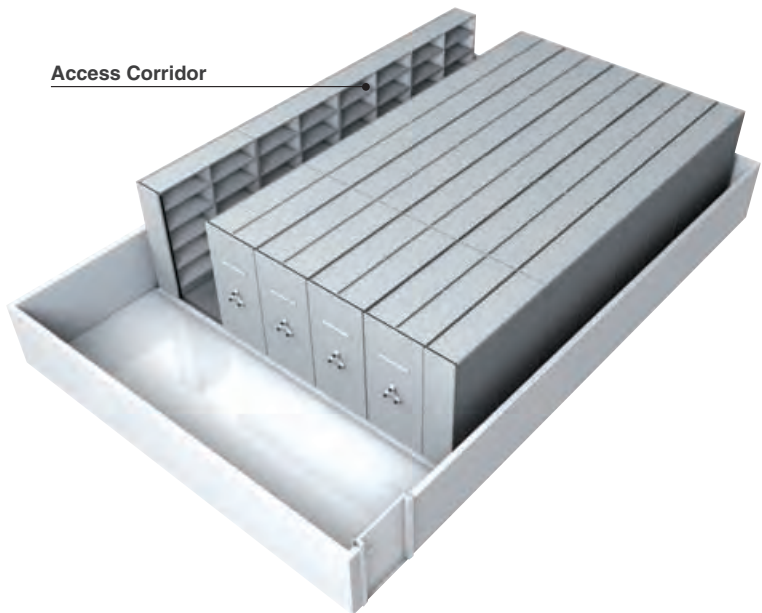

3

**EunMobile** adapts perfectly to the layout of any premises, integrating pillars, ventilation systems, etc. in the design.

Pillars

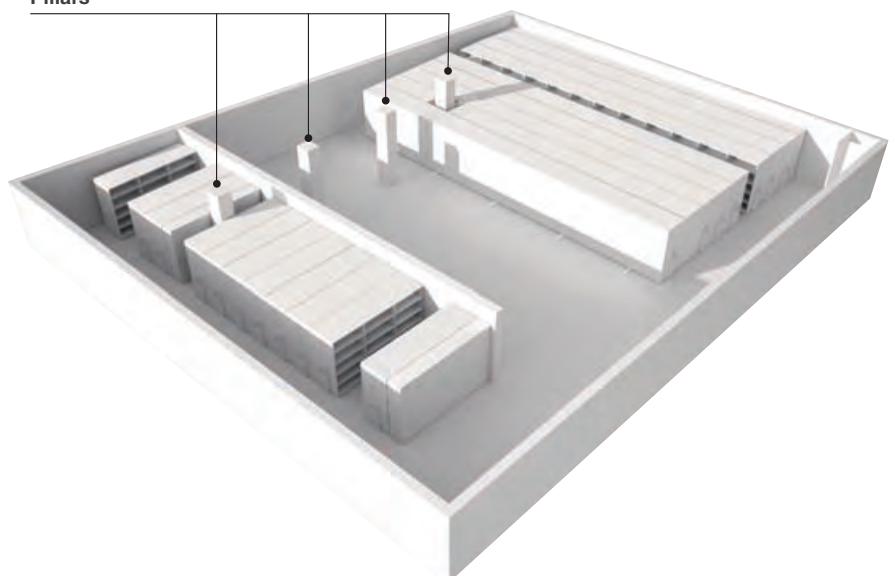



Double ramp rails

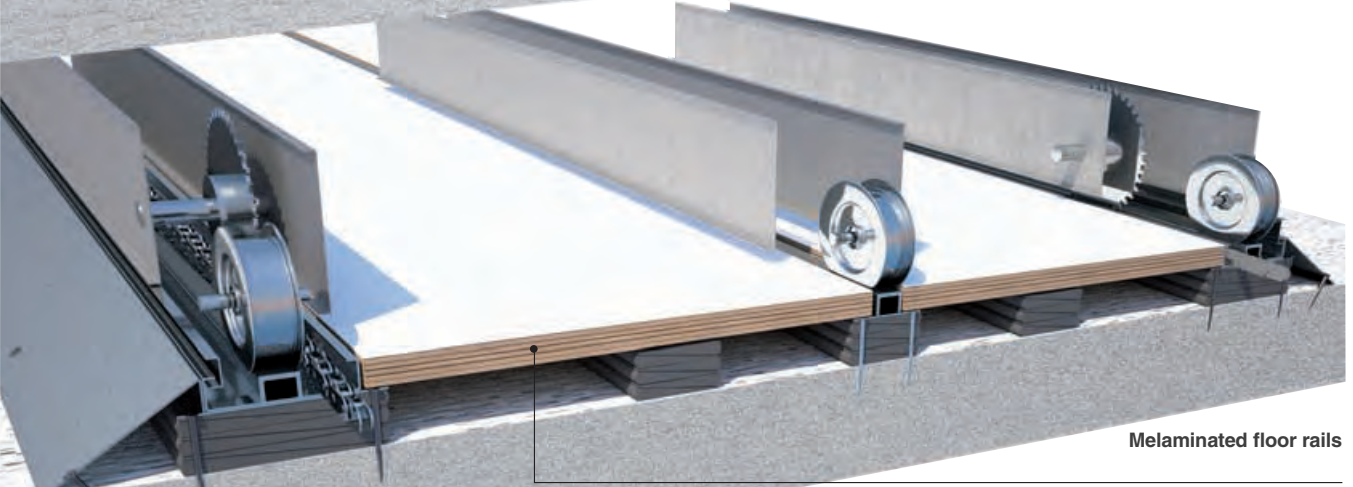

Melaminated floor rails

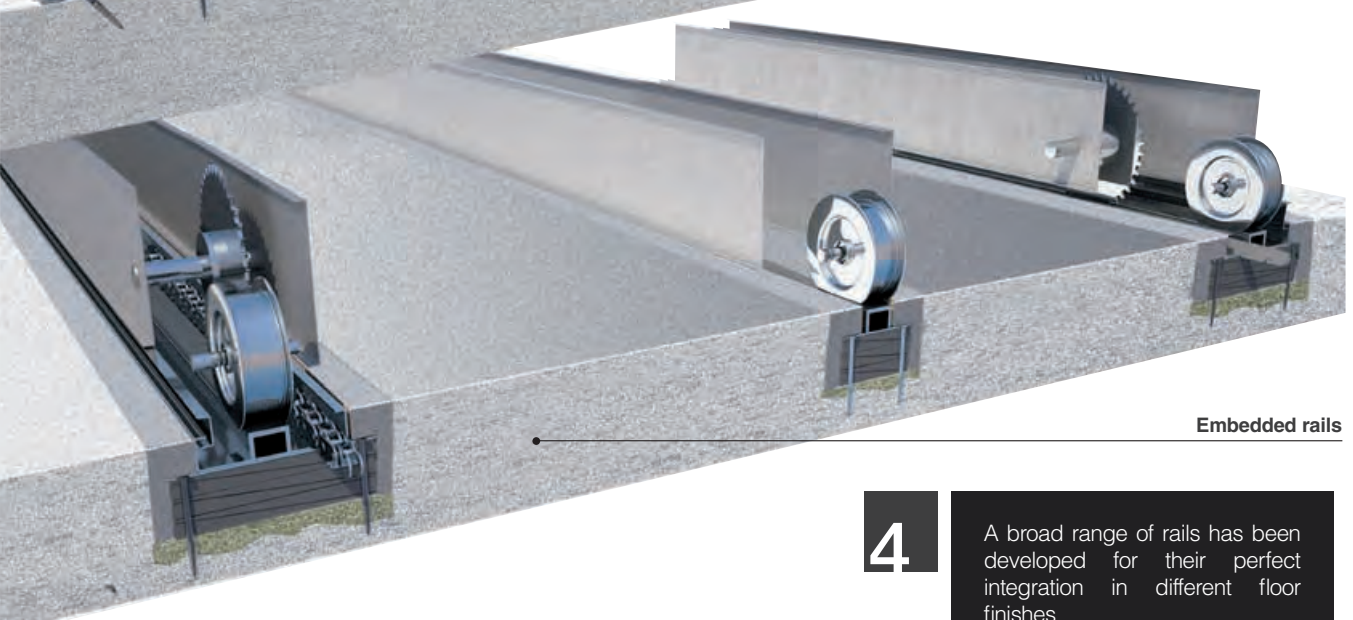

Embedded rails

4

A broad range of rails has been developed for their perfect integration in different floor finishes.

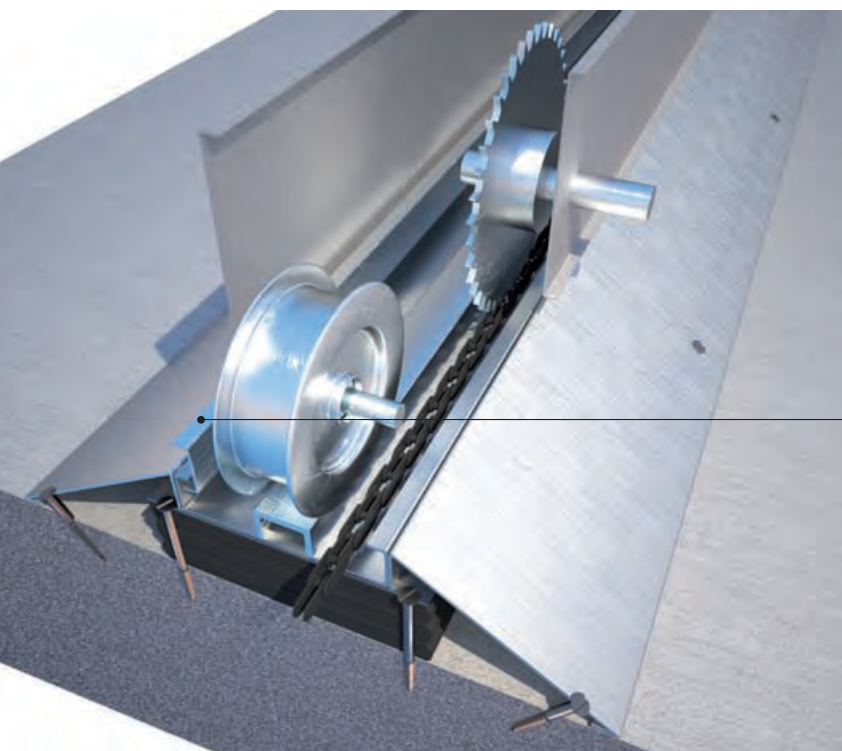

Anti-tilt syst.

5

These carriage rails have been afforded the maximum technical guarantees in safety such as: guide and anti-tilt system and housing for the drive chain.

6

Moreover, **EunMobile** can be delivered with a system that can block the corridor after each movement to avoid unwanted carriage movements during use.



7

The protection of the carriage contents is guaranteed by means of the possibility of blocking the filing system with a lock on the fixed carriage (cuts off the power to the system) and by fitting rear panels (single carriage) or sliding doors (double carriages) on the last carriage.



8

Insulation of the contents from humidity and dust is guaranteed by means of designs based on rubber and metal sections in strategic places.

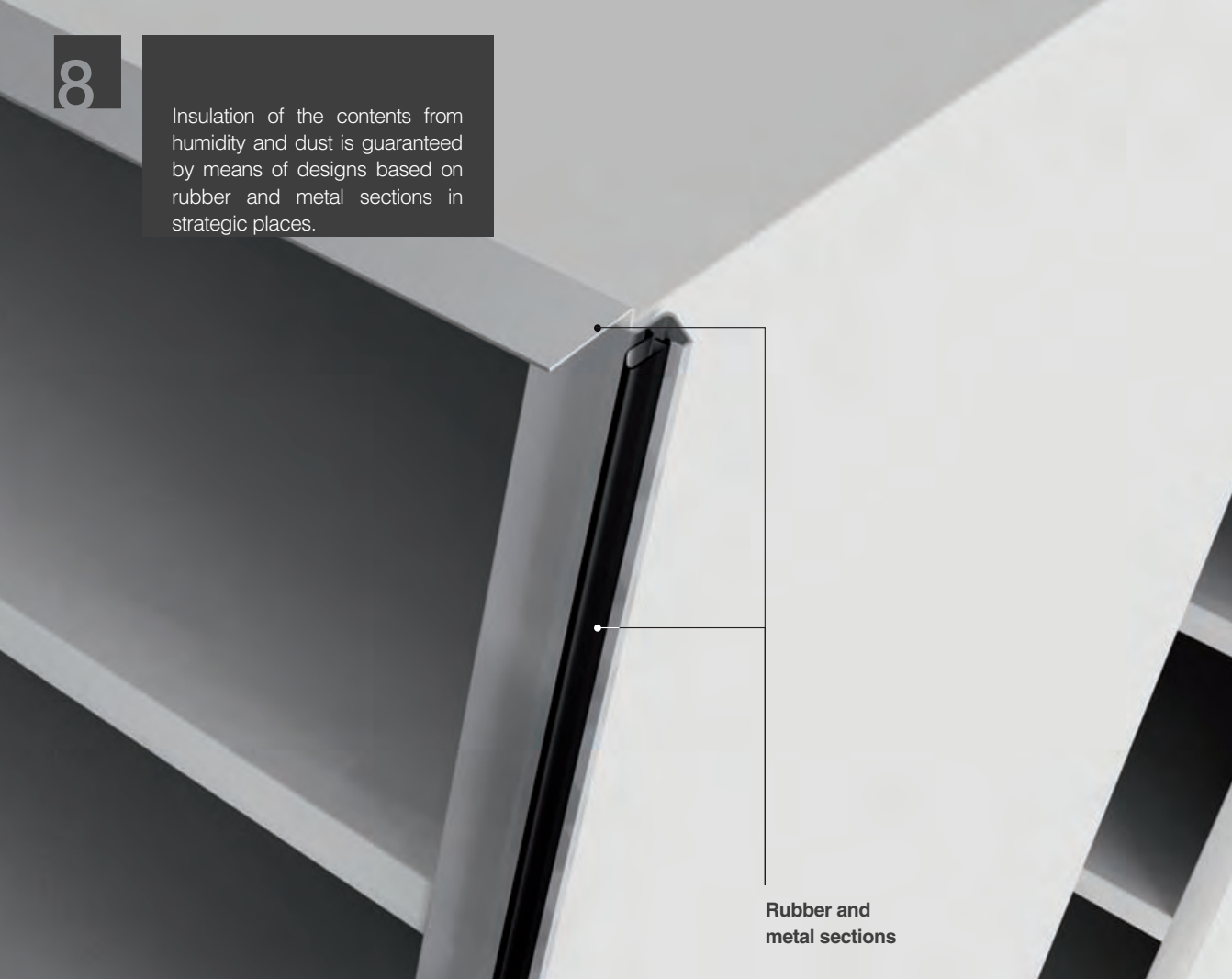

Rubber and metal sections

9

The smooth carriage movement guarantees minimum effort in carriage movement thanks to smart drive systems capable of moving weights of up to 40.000 kg.

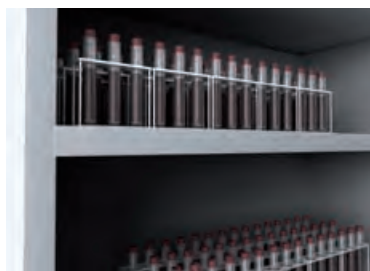

Single demultiplication system .....	15.000 Kg
Double demultiplication system.....	30.000 Kg
Triple demultiplication system.....	40.000 Kg

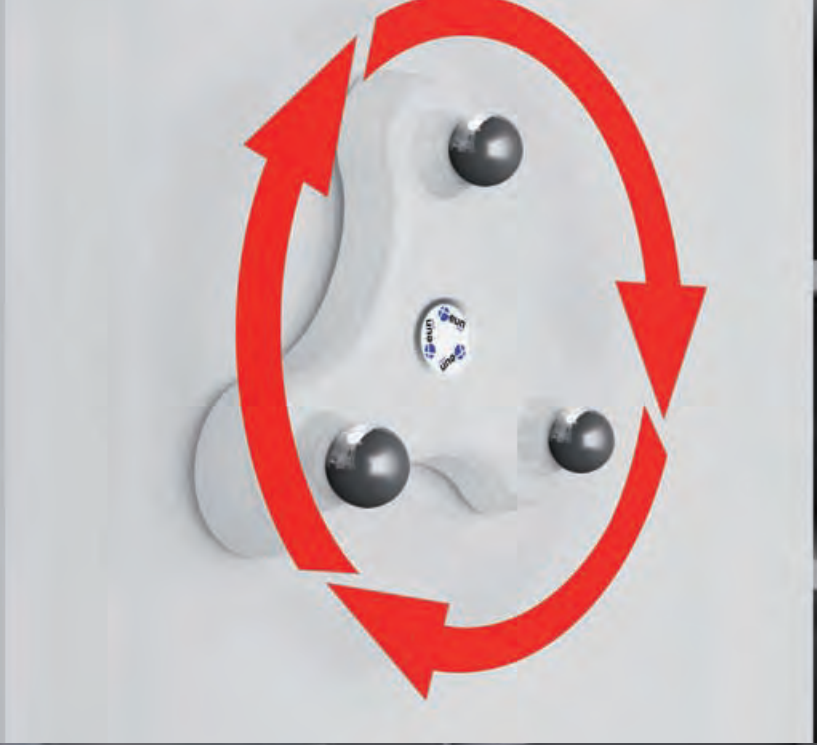

10

This smooth movement is reflected in an ergonomic wheel design for making movements, particularly designed to maximise the application of strength.





# 11

Aesthetic appeal is not at odds with technology, and the product delivers the possibility of having different personalisable finishes in terms of colours used, materials, drill holes, etc., on front panels.

# 12

The resistance of the carriage structure has been optimised to achieve shelves capable of supporting weights of 200 kg, distributed evenly and with the possibility of adding an additional rear stop.

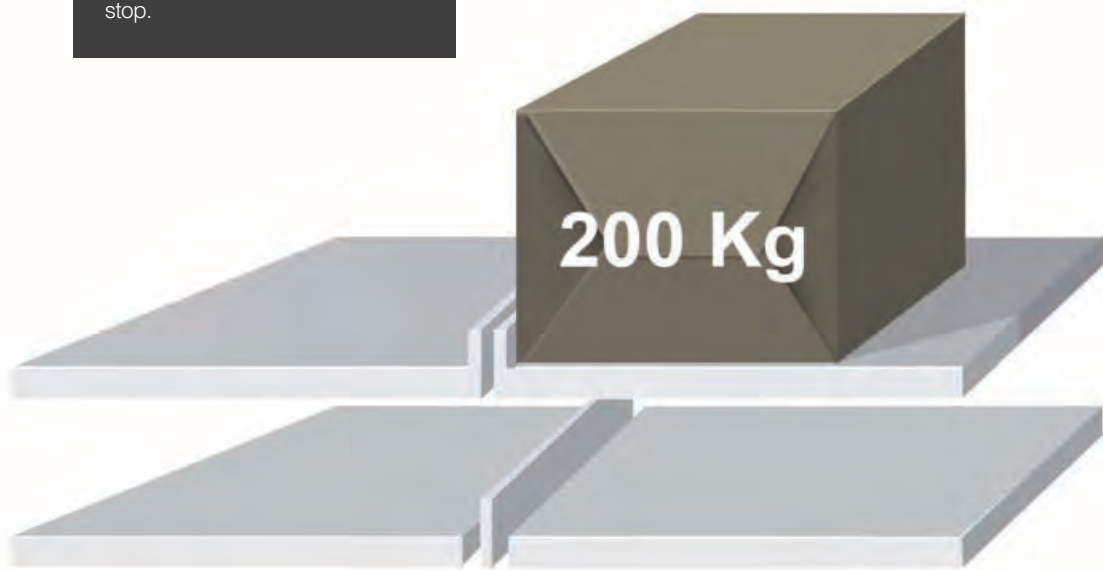

13

Ergonomics and safety for the hand offering a product without rough or cutting edges. Result: Soft to touch, and a rugged shelf.



14

The system's inner ventilation is guaranteed through the possibility of using perforated columns.



15

A very broad range of product sizes is on offer to facilitate their adaptation to any infrastructure.  
W x H x D  
(Width x Height x Depth)







16

Smart shelf hooks to guarantee secure and height-adjustable, effortless fixing, with no tools needed.

17

Very low fire conductivity and zero static electricity.  
Fire resistance (M1)



18

The system guarantees a smooth shutdown and start-up, without brusque jolts, vibrations or clashing carriages, which makes for greater durability of all the product parts.



 **eun mobile**  
eun grupo



 **eun Matic**  
eun grupo



19

This first phase of evolution in the “mobile” concept of **Eun Grupo** can also be transformed into the 2nd phase of evolution, i.e. **EunMatic**, bringing in motorisation functionalities in a second phase, and even in a 3rd phase, providing this motorisation with software-driven electronic control through the **EunTronic** product.



20

High-quality, durability and perfect finishing.

# Accessories



**01**

Shelf with stop - Standard



**02**

Shelf without stop



**03**

Perforated shelf

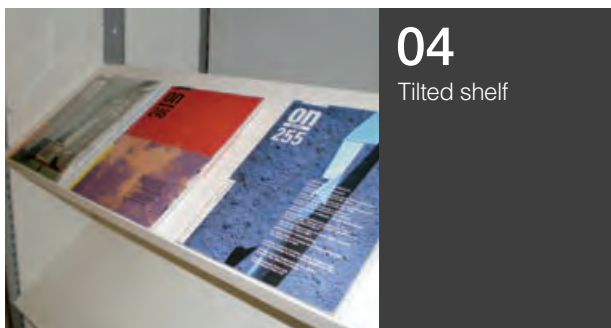

**04**

Tilted shelf



**05**

Shelf with reinforcement

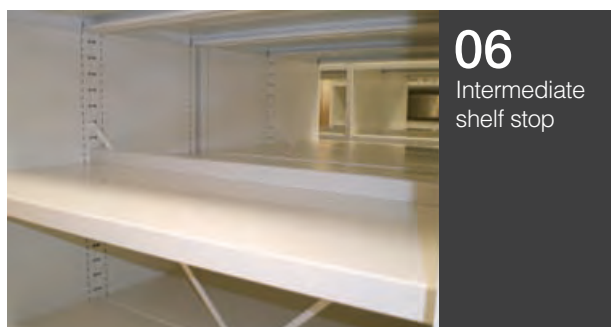

**06**

Intermediate shelf stop



**07**

Reference tray

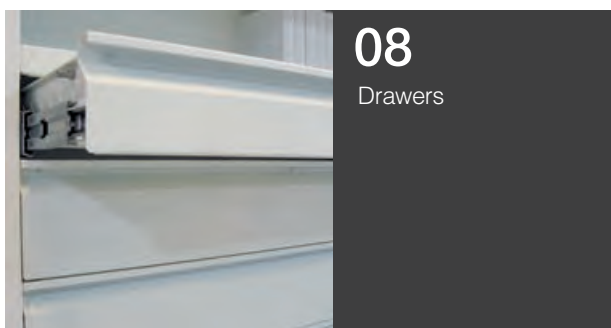

**08**

Drawers

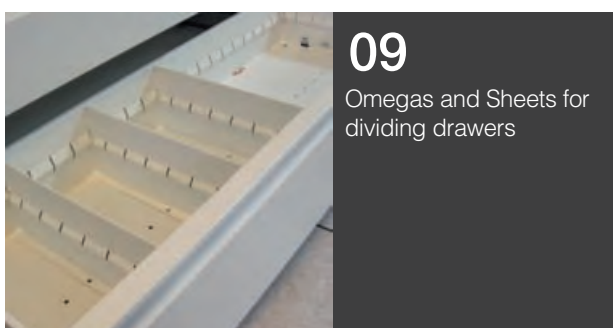

**09**

Omegas and Sheets for dividing drawers

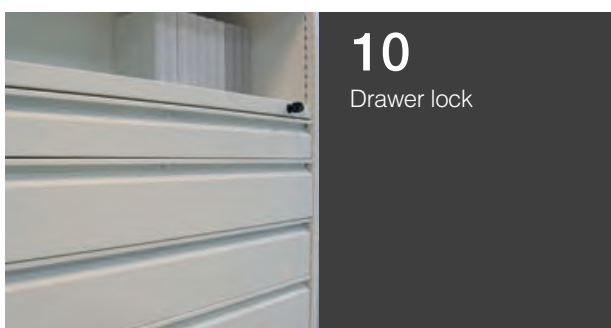

**10**

Drawer lock

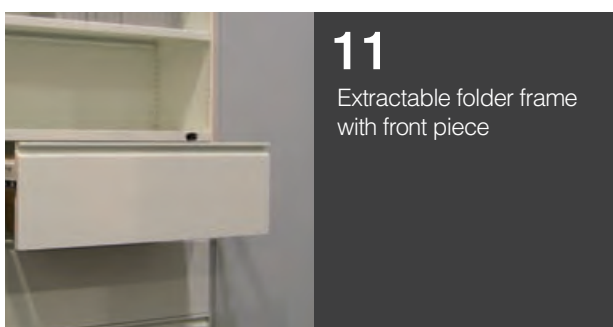

**11**

Extractable folder frame with front piece

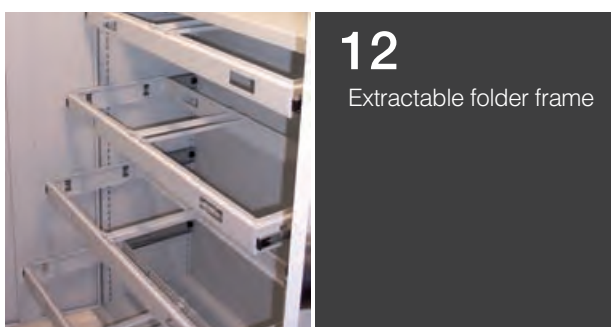

**12**

Extractable folder frame

21

Very broad range of accessories (stops, drawers, separators, etc.) to guarantee maximum adaptability to any need.

13

Container warehouse



14

Collapsible display window



15

Rod-type movable hanging separator



16

U-type movable separator



17

Fixed separator

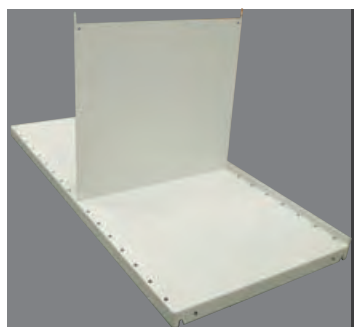

18

Installation locking system – Sliding doors

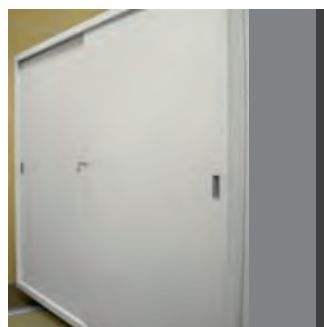

19

Installation locking system – Back pieces



20

Folders and Subfolders



21

EunMobile wheel



22

Class E EunMobile wheel



23

Locking system





## filing and storage systems



## lockers and cubicles



## office equipment



## less space, more possibilities

Space for filing and storage is essential in the vast majority of businesses. This can create a problem, since a large amount of space must often be set aside for this purpose. **Eun Grupo** understands these problems and has developed cutting-edge solutions to provide specific answers for all types of projects, whether private spaces, such as offices and businesses in general, or public places including libraries, museums, universities and health centres. From the outset, the primary activity of our company has focused on the design and manufacture of products to make day-to-day management easier, offering the highest quality in all our classification systems. Our philosophy has always stressed continuous supervision in all of the various creative phases: – study, planning, manufacture, marketing and assembly – providing comprehensive services throughout. In order to ensure the quality standards that **Eun Grupo** requires for all of its products, the company has invested in modern manufacturing processes and two production plants. Another area that has received a great amount of attention is Research and Development, with more than 500 m<sup>2</sup> of space, backed by a strong team of highly qualified employees to guarantee quality and service. A quality that was awarded the ISO 9001 certification. Moreover, in our efforts to ensure better quality of life for the entire community we have implemented the ISO 14001 Environmental management system. Painsstaking customer service and fast and efficient service at the hand of genuine professionals has placed **Eun Grupo** among the elite of companies working to provide the highest quality products possible. Today, **Eun Grupo** has three companies: **Eun Sistemas s.l.**, **Eun Madrid s.l.** and **Eun México s.a. de C.V.**, located in Beasain (Guipuzcoa), Madrid and Mexico City, respectively. Seventy percent of the production of these sites is earmarked for the domestic market. But we should also mention that **Eun Grupo** has made a commitment to expand its markets, as seen in the long list of countries already familiar with the quality of our products: France, Greece, Portugal, Belgium, Morocco, Tunisia, Brazil, Hong Kong, United Arab Emirates, Chile, Puerto Rico and Mexico, among others.

## Quality certificates



Certificado #952608

Since our company was founded, the concepts of innovation and quality have gone hand in hand with a single strategy, offering our clients guaranteed results. These efforts were rewarded with the ISO 9001 Certificate, subsequently complemented with the ISO 14001 certificate, acknowledging its environmental management system.









# information application form

Yes, I would like to be visited by a technical sales representative of **Eun Grupo**.

Yes, I would like to receive information on the following products.



- K100
- K100 PTC



- Asti



- MovilEun
- MovilEun Clase E
- MovilEun Lateral



- EunMatic



- EunTronic
- EunTronic Avant
- Magnus
- Keeper



- EunLogic® - Store
- EunLogic® - File



- EunEuki M
- EunEuki F
- EunEuki P
- EunEuki C



- EunOffice K100

## personal details

Company \_\_\_\_\_ VAT no. \_\_\_\_\_

Activity \_\_\_\_\_ No. of employees \_\_\_\_\_

Name and surname(s) \_\_\_\_\_

Position \_\_\_\_\_

Address \_\_\_\_\_

\_\_\_\_\_ No. \_\_\_\_\_

Post/Zip code \_\_\_\_\_ Town/City \_\_\_\_\_

Province \_\_\_\_\_ Country \_\_\_\_\_

Tel. no. \_\_\_\_\_ Fax: \_\_\_\_\_

E-mail: \_\_\_\_\_

To request information with no commitment whatsoever, contact us or fill in this form in block capitals and send it by fax to **+34 943 889 741** or by e-mail to: **comercial@eun.es**



# Movinord

Office Concept

Λεωφ. Κηφισίας 256, Χαλάνδρι Τ.Κ. 152 31  
ΤΗΛ. +30 210 6141550, 210 2532233, FAX: +30 210 2532235

Λαέρτου 22, Πυλαία, Θεσσαλονίκη, Capital Trade Center, κτίριο C  
ΤΗΛ./Fax. +30 2310 472584, ΚΙΝ. +30 6947004736

[info@movinord.com.gr](mailto:info@movinord.com.gr)  
[www.movinord.com.gr](http://www.movinord.com.gr)