

COMMON design **Naoto Fukasawa** 2013

Elegant modular system of seats and benches for the lounge. Its configuration allows you to create a timeless landscape because its high-density foam retains its pure lines, even after intensive use. Its feet and auxiliary tables are done in natural oak hardwood, reminiscent of the modern classics.

TECHNICAL INFO

Inner structure in solid wood and perforated top of microparticles low-formaldehyde chipboard covered by expanded polyurethane foam and polyester fiber. Legs in matt varnished natural beech.

Tables constructed with a natural oak column and a lacquered MDF top with the finishes of the collection.

Inner structure in solid wood and perforated top of microparticles low-formaldehyde chipboard covered by expanded polyurethane foam and polyester fiber.

Legs in matt varnished natural beech.

Tables constructed with a natural oak column and a lacquered MDF top with the finishes of the collection.

FINISHES

Check upholstery samples. Not produced in leather.

Table

Legs



natural
beech

CERTIFICATES



COMMON design Naoto Fukasawa 2013

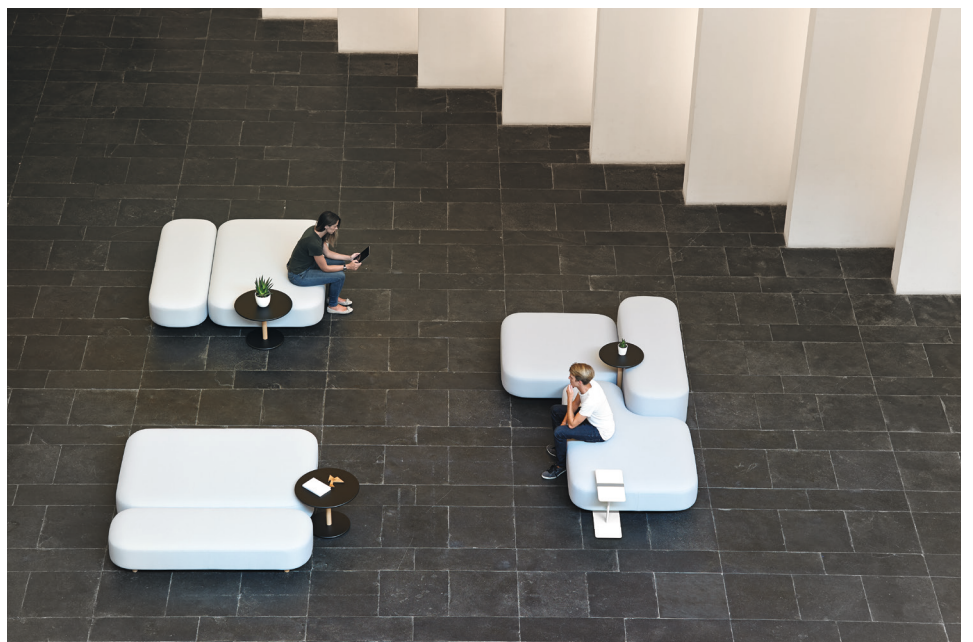

BENCH + TABLE

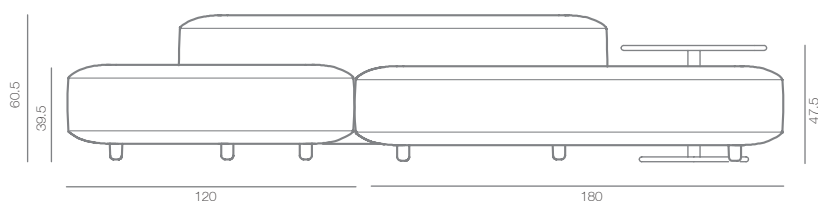

COMMON design Naoto Fukasawa 2013

COMMON - SEATS

BENCH 240

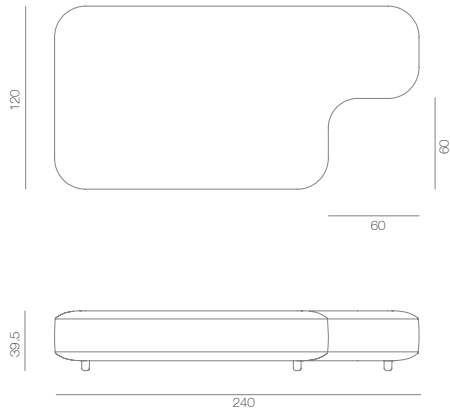

BENCH 120

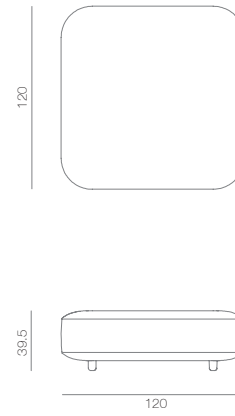

BENCH 180

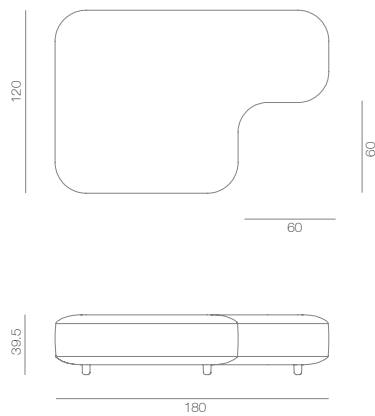

BENCH 180

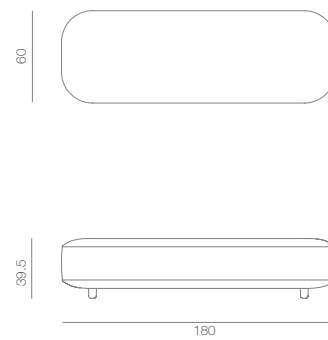

BENCH 180

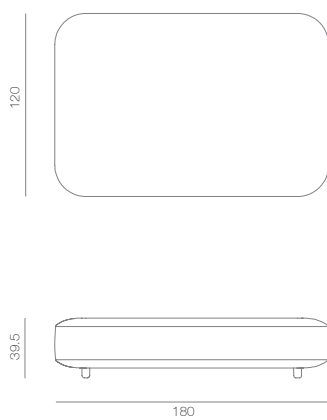

BENCH 180

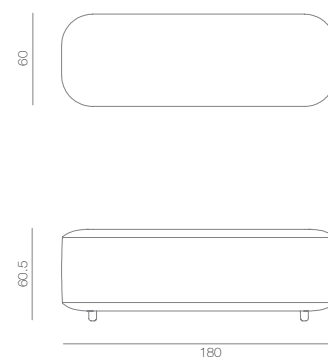

COMMON design Naoto Fukasawa 2013

BENCH 120

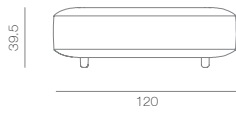

BENCH 120

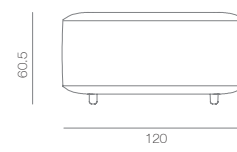

PROJECTS

Auditorio de Castellón | Molino Real | Hotel Caro | DE House | Uralchem Headquarters | Hub Showroom | ViccarbeStudio | Buro Modern

NAOTO FUKASAWA Japan

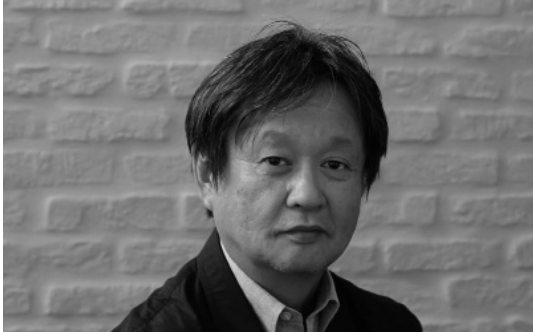

Naoto Fukasawa, born 1956 in Yamanashi Prefecture, Japan, studied art and 3D-design at Tama Art University in Tokyo. He worked as a designer for Seiko-Epson until 1988 and for ID-two in San Francisco from 1989-96. After returning to Japan in 1996, he was head of the firm IDEO's Tokyo office and several years later he opened his own office, Naoto Fukasawa Design, in Tokyo. Since 2001, when he also became a consultant for the MUJI company, his primary focus has been the design of household products and electronic devices.

Fukasawa collaborates with world leading companies and brands in such countries as Italy, France, Germany, Switzerland, Spain, Scandinavian countries and Asian countries while consulting Japanese leading companies locally. His area of work is broad and he works with various fields in design beyond categories. Consulting works for Japanese companies are mainly focused on evaluating their cooperate strategies in line with the mean of sociality and how we define quality of life in order to direct the companies towards where society is inevitably heading. Such consulting work extends as far as to visualise design for their products which marks the company's social responsibilities as well as to visualise their cooperate strategies and Fukasawa's work for consulting has led them to many successful results.

PRODUCTS

COMMON table