

---

PLATFORM

design Arik Levy 2013

---

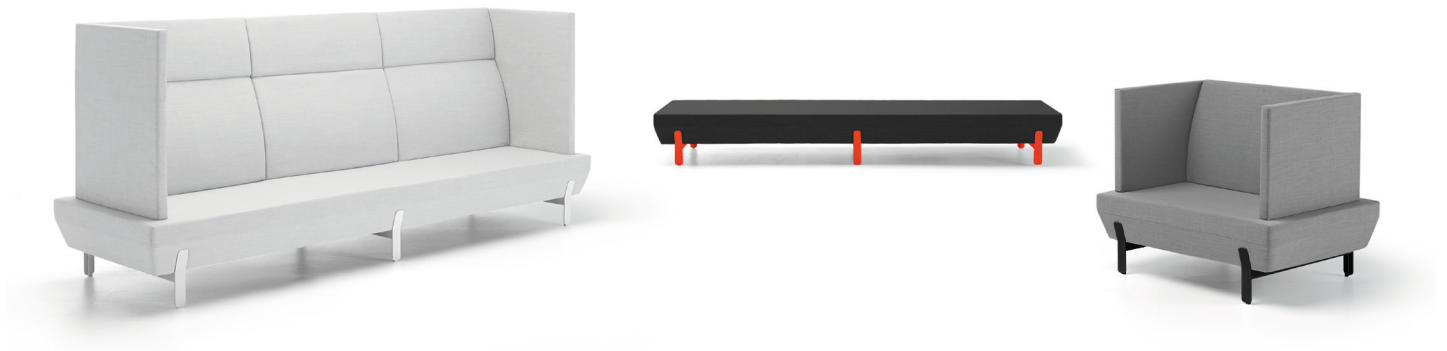

Collection of seats with varying back heights ideal for unique lounges. Its elegant presence and meticulous attention to comfort with the multiple combinations of finishes and bases make Platform an iconic product.

---

TECHNICAL INFO

Solid wood + MDF covered in non-deformable expanded polyurethane and polyester fibre.  
Calibrated steel base lacquered in thermoset epoxy polyester in white, black and fluorescent orange.

---

FINISHES

Check upholstery samples. Platform is not available in leather upholstery.

Base



white  
RAL 9003



black  
RAL 9006



orange  
RAL 3026

---

CERTIFICATES



---

PLATFORM

design Arik Levy 2013

---

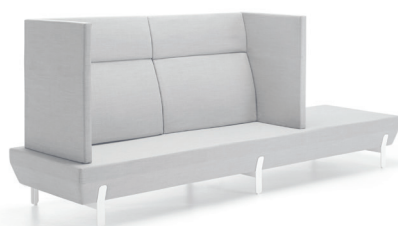
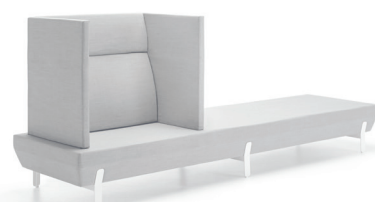

---

PROJECTS

Mof Real I

PLATFORM

design Arik Levy 2013

SEATS:

POUF

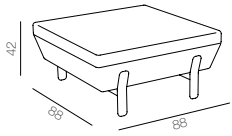

ONE SEAT

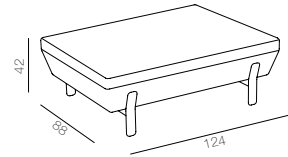

TWO SEATS

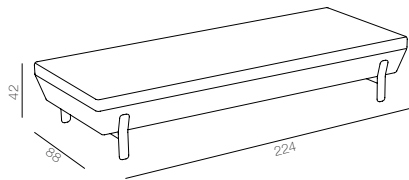

THREE SEATS

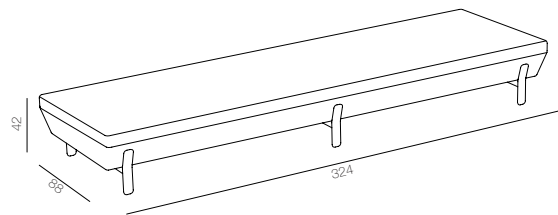

BACKS:

LOW BACKREST

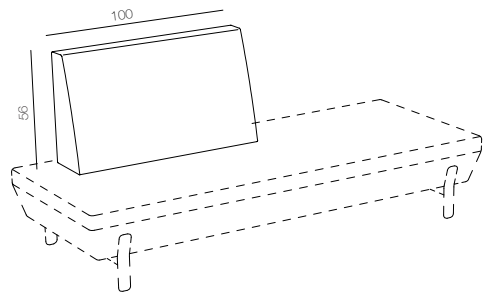

HIGH BACKREST

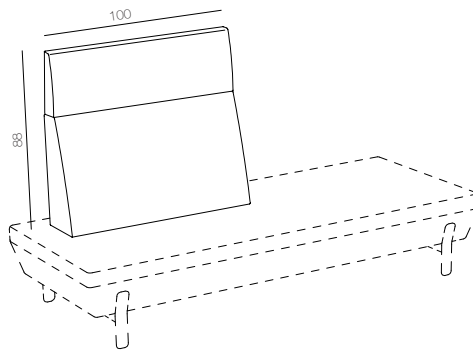

ARMS:

LOW SIDE BACK

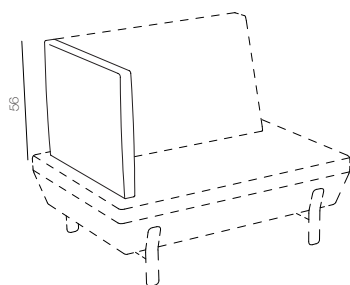

HIGH SIDE BACK

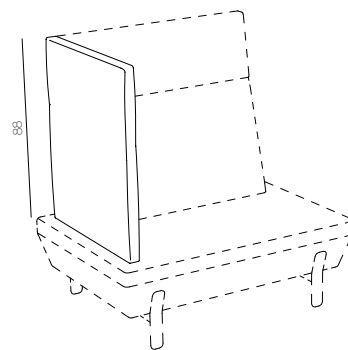

COMPOSITION 1

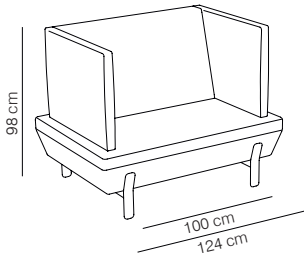

COMPOSITION 4

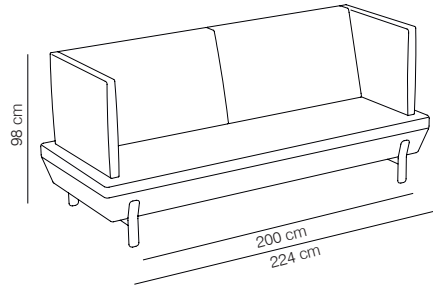

COMPOSITION 2

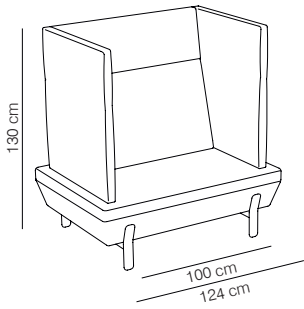

COMPOSITION 5

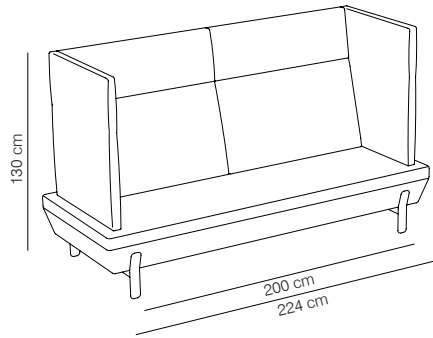

COMPOSITION 3

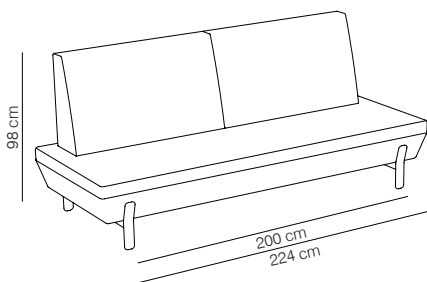

COMPOSITION 6

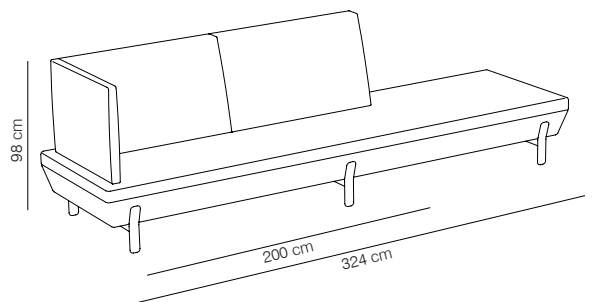

COMPOSITION 7

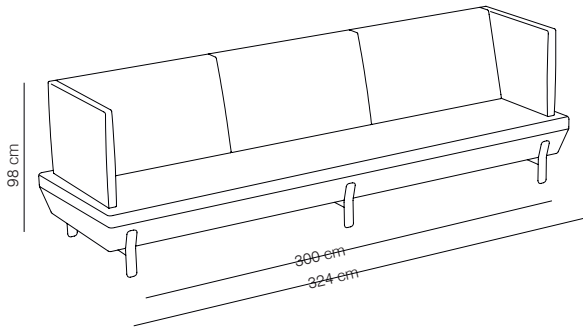

COMPOSITION 10

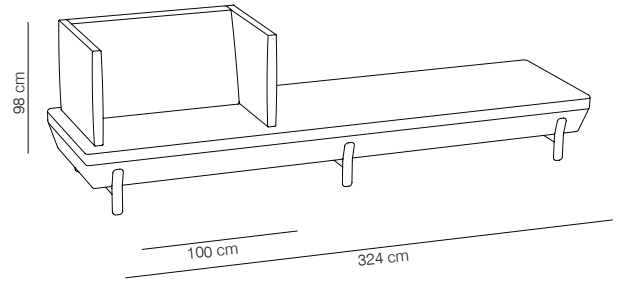

COMPOSITION 8

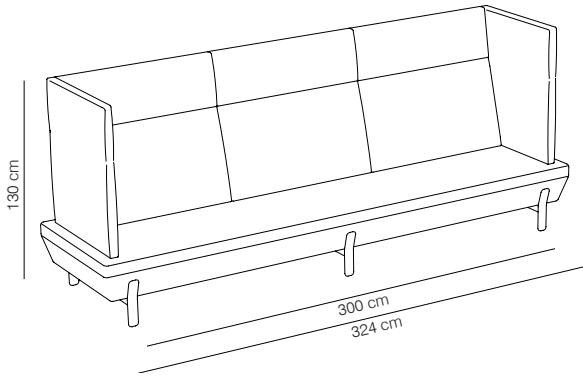

COMPOSITION 11

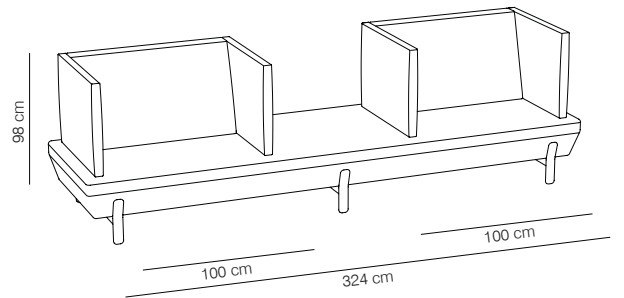

COMPOSITION 9

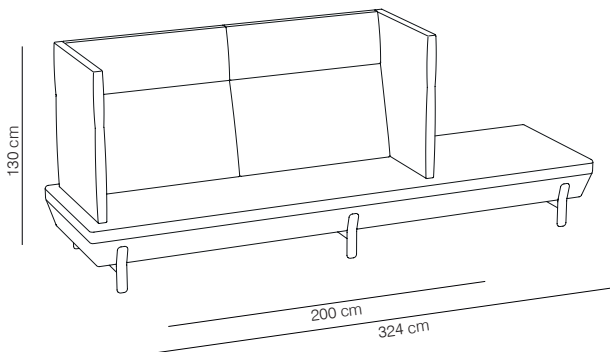

COMPOSITION 12

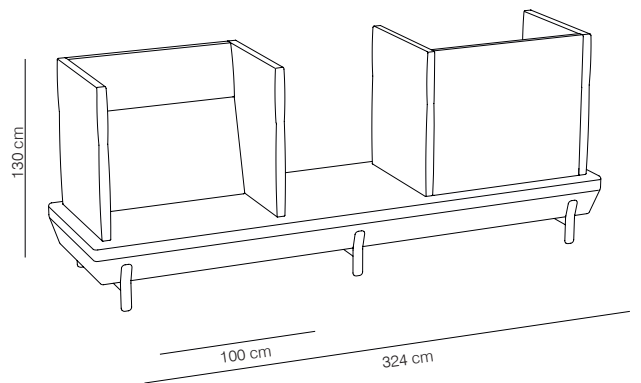

COMPOSITION 13

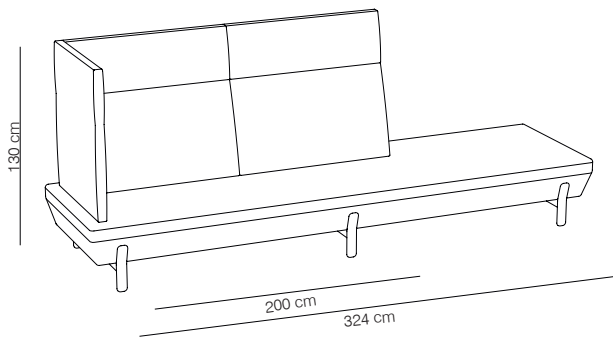

COMPOSITION 14

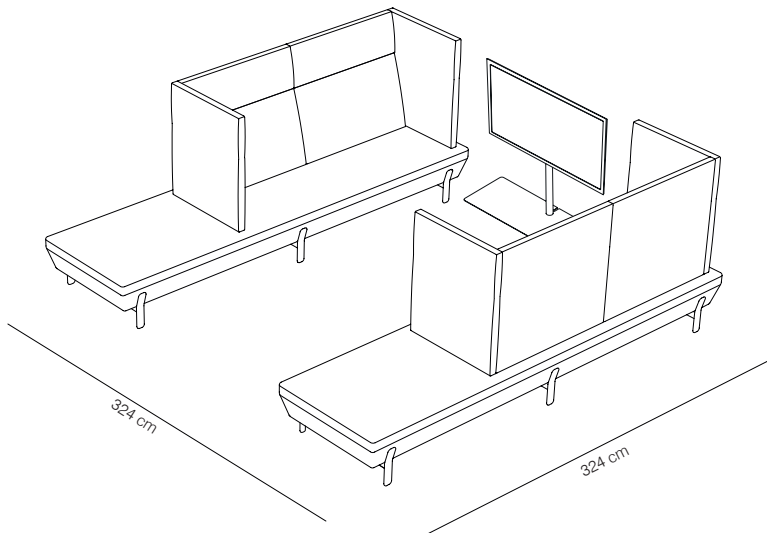

---

**ARIK LEVY** Israel

---



Tel-Aviv, 1963.

At the age of 27 Arik leaves behind his graphic design studio and surfboard shop for Europe.

In 1991 he graduates with distinction in Industrial Design from the Art Center Europe in Switzerland. After winning the Seiko Epson Inc. competition, Arik begins his career as a professional designer and participates in several design exhibitions in Japan.

Upon returning to Europe, Arik introduces his ideas, innovative concepts and installations to contemporary dance and opera set design around the world.

From his Paris based company L design, together with his partner Pippo Lionni and their team of designers, Arik develops projects in industrial, interior and graphic design for the European and international market. His technical skills and creativity, allow Arik to work on a variety of subjects and disciplines from product development, lighting design and corporate identity to packaging, point of purchase design, signage, exhibition, interior and set design.

Arik participates in many exhibitions and shows in museums, alternative spaces, galleries and fairs worldwide and several of his products can be found the permanent collections of the most prestigious museums and institutions.

He works both as a scientist and a poet. Through innovation, simplicity and experimentation he translates concepts into products, space and experience.

Among his latest realizations the impressive crystal-ware collection Intangible for Baccarat, introduced to the public during the last Maison & Objet fair in Paris in January 2007.

Among Ldesign/Arik's clients: Viccarbe, Vitra, Vizona, Desalto, Ligne-Roset, Cinna, Seiko Epson Inc., Gaia&Gino, Boutet, Sentou, L'Oréal, Serralunga, Baleri Italia, Lanvin, Boucheron, Alon Segev Gallery, Belux, Elica, Ansorg, Renault, Tronconi, Sector Sport Watches, Designers Carpets, Tai Ping, Baccarat, Galeries Lafayette, MGX Materialise, Swedese, Softline Allkit, Bitossi, ENO, Zanotta, Bernhardt, Council, Kvetna ...

---